

# Second Grade

## AMI Days Work Instructions

For each AMI (Alternate Method of Instruction) day, please have your student complete the packet at their own pace. You will receive an email from us to complete the specific day's packet (Ex: Please complete Day 1 worksheets). They may receive help if needed. When finished, please make sure to return the packet to school the next day.

If you have any questions at all, please contact your child's teacher using the email address below:

Mrs. Plummer: [tplummer@seymourschool.net](mailto:tplummer@seymourschool.net)

Ms. Stacey: [jstacey@seymourschool.net](mailto:jstacey@seymourschool.net)

Mrs. Johnson: [tjohnson@seymourschool.net](mailto:tjohnson@seymourschool.net)

Thank you for your continued support of your child's education!

Second Grade Teachers,  
Mrs. Plummer, Ms. Stacey, Mrs. Johnson

# Day 1

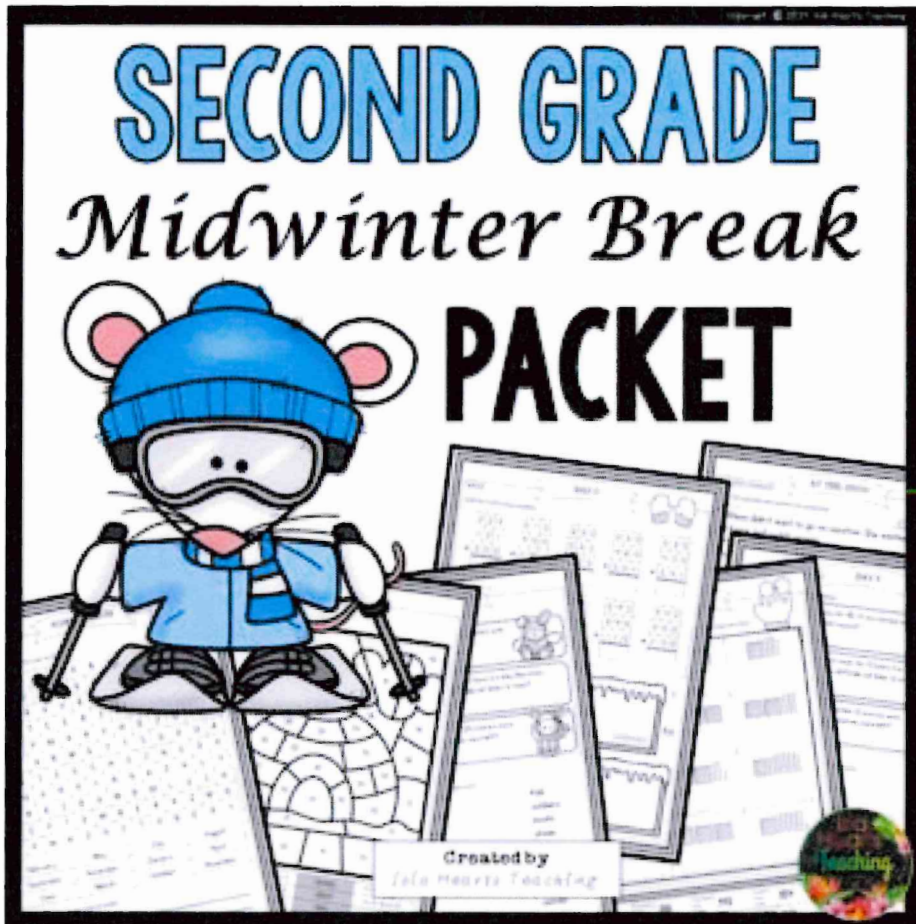

# 2<sup>nd</sup> Grade



Name \_\_\_\_\_

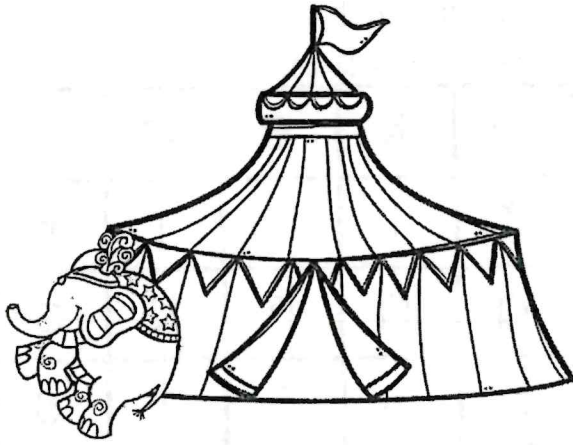

The circus was coming to town. They set up a big red and white tent. Then the animals came out. The elephant was first. Then the lions and tigers came out in cages. Tom was very excited to go to the circus.

Color the circle and then find the answer in the passage. Highlight the answer or the clue using the same color crayon.

1.  How did Tom know the circus was in town?

\_\_\_\_\_

-----

\_\_\_\_\_

2.  What color was the tent?

\_\_\_\_\_

-----

\_\_\_\_\_

3.  Which animal came out first?

\_\_\_\_\_

-----

\_\_\_\_\_

4.  Why did they keep the lions and tigers in cages?

\_\_\_\_\_

-----

\_\_\_\_\_

5.  What do you like about the circus?

\_\_\_\_\_

-----

\_\_\_\_\_



Name \_\_\_\_\_

# Grammar Word Search!

Directions: Find the nouns, verbs and adjectives in the word search.

Use the color code to highlight each word.

Bonus: Write the words in ABC order.

s	n	o	w	f	l	a	k	e	a	a	s
s	t	o	o	b	c	m	i	t	t	e	n
o	t	m	a	p	h	a	n	r	u	a	o
u	h	s	e	t	a	k	s	s	t	e	w
p	r	a	a	a	i	a	s	m	o	i	b
d	o	c	t	o	r	i	p	i	l	s	a
p	w	a	a	p	t	a	a	e	a	a	l
r	a	t	l	s	o	f	t	t	g	a	l
e	a	c	l	o	u	d	y	i	a	u	a
t	s	h	a	k	e	g	a	h	a	a	h
t	r	o	l	l	o	p	a	w	a	a	a
y	a	s	k	a	t	i	n	g	r	u	n



doctor	roll	huge
skating	cloudy	snowflake
tall	snowball	wet
chair	white	soft
run	skates	throw
pretty	slip	soup
map	mitten	shake
catch	boots	tissue

Name \_\_\_\_\_

# Addition Word Problems

Directions: Read the word problem and answer the questions.



## Problem:

Paul and Jane want to earn \$95 to buy the new Zipper Lightning Fast sled! Jane earns \$27 dollars by walking the neighbor's dogs. She also earns \$19 by helping her mother around the house. Paul earns \$34 by shoveling snow for the neighbors. He also earns \$16 by helping his father.

1. How much money did Jane earn altogether?

2. How much money did Paul earn altogether?

3. How much more money did Paul earn than Jane?

4. Which two jobs earned the most money? How much did they earn together?

5. Which two jobs earned the least money? How much did they earn together?

6. How much money did Jane and Paul earn altogether?

7. Do they have enough money to buy the Zipper Lightning Fast sled? If not, how much more do they still need?

8. If Paul didn't shovel snow, how much more money would they need to reach their \$95 goal?



Name: \_\_\_\_\_

## Using a Number Line!

Directions: Use the number line to find the missing number.

Start at 9 and jump to 15.

$$9 + \underline{\quad} = 15$$

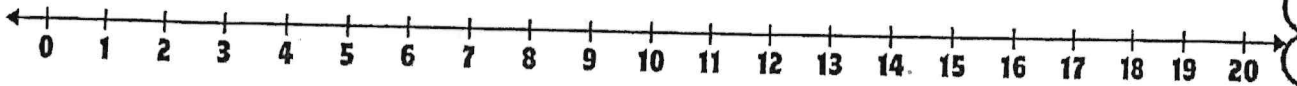

Start at 3 and jump to 10.

$$3 + \underline{\quad} = 10$$

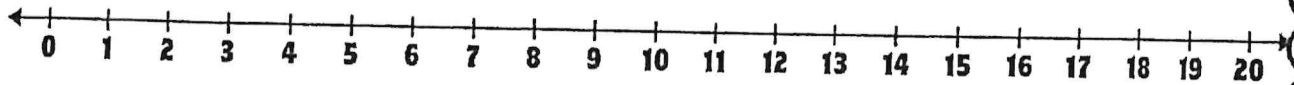

Start at 7 and jump to 14.

$$7 + \underline{\quad} = 14$$

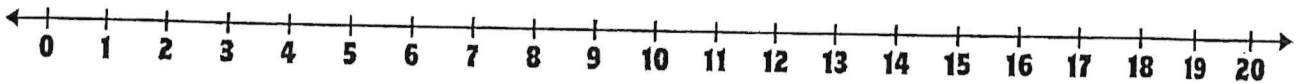

Start at 8 and jump to 17.

$$8 + \underline{\quad} = 17$$

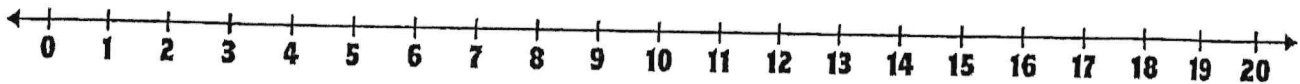

Start at 11 and jump to 18.

$$11 + \underline{\quad} = 18$$

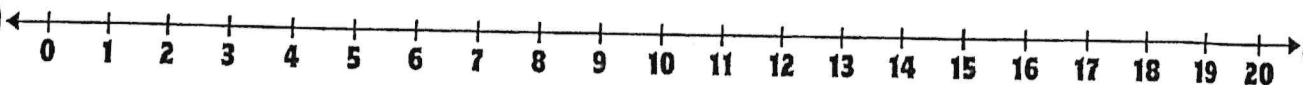

# How Arctic



# Animals



# Stay Warm

Name: \_\_\_\_\_

In the winter, we wear layers of clothing to protect our bodies from the harsh, cold weather. But how do arctic animals stay warm? Easy—they all have extra layers of blubber (fat) that keep the cold air out. Let's investigate!

Boo...

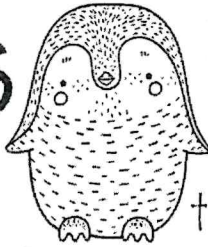

## Materials List:

1 bowl per table or group that is filled with cold water and many ice cubes

1 empty Ziploc sandwich bag per student

1 Ziploc sandwich bag filled with shortening per student

## Step One:

Place your bare hand into the bowl of ice water for as long as you can. Record your notes here:

I lasted \_\_\_ seconds. It felt \_\_\_\_\_

---

---

---

## Step Two:

Place your bare hand into an empty Ziploc bag. Then, place this bagged hand into the Ziploc bag that is filled with shortening. Finally, place this heavily covered hand back into the bowl of ice water for as long as you can. Record your notes here:

I lasted \_\_\_ seconds.

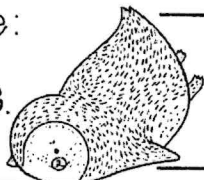

## Fully complete this thought:

Having my hand heavily covered by a material that is similar to arctic animals blubber taught me...

---

---

---

---





# Music AMI Day 1

Teacher: Mrs. Rechtfertig



Email: [arechtfertig@seymourschool.net](mailto:arechtfertig@seymourschool.net)

Office hours: 9am-1pm

Name: \_\_\_\_\_

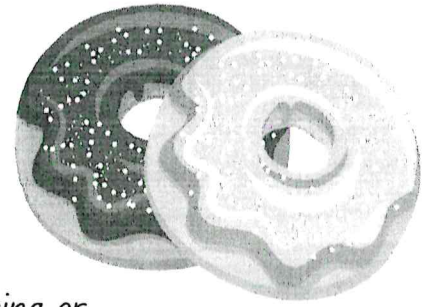

In music, there are symbols that tell you how loud or quiet to sing or play. This list shows you the symbol, what it is called, and what it means.

***ppp***

Pianississimo

Very, Very Quiet

***pp***

Pianissimo

Very Quiet

***p***

Piano

Quiet

***mp***

Mezzo Piano

Medium Quiet

***mf***

Mezzo Forte

Medium Loud

***f***

Forte

Loud

***ff***

Fortissimo

Very Loud

***fff***

Fortississimo

Very, Very Loud

Name: \_\_\_\_\_

# A Tasty Musical Experience



Directions: Identify the dynamic in the donut. Write its name on the space below.

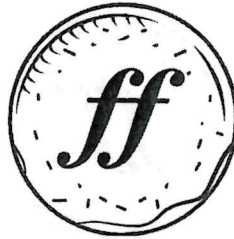

Piano

.....

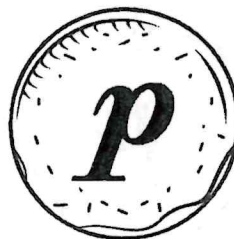
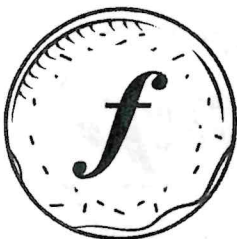
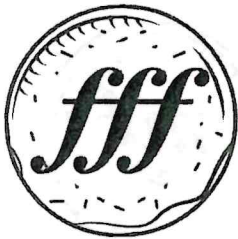

.....

Name: \_\_\_\_\_

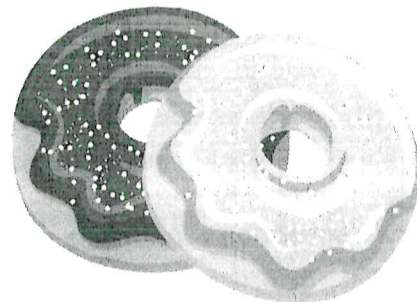

Directions: Identify the dynamic in the donut. Write its meaning on the space below.

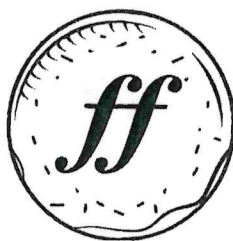

Quiet

.....

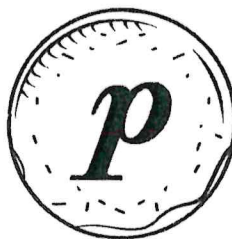



## ART AMI ACTIVITIES 1&2



Mrs. Dean

E-mail: [adean@seymourschool.net](mailto:adean@seymourschool.net) (preferred method of communication)

Phone: 417-207-3844

I will be available for contact from 9 a.m. to 1 p.m.

(If messaged outside time above I will try to respond within an hour)

When completing Art activities feel free to use whatever materials you have available.





## Cubism Self Portrait

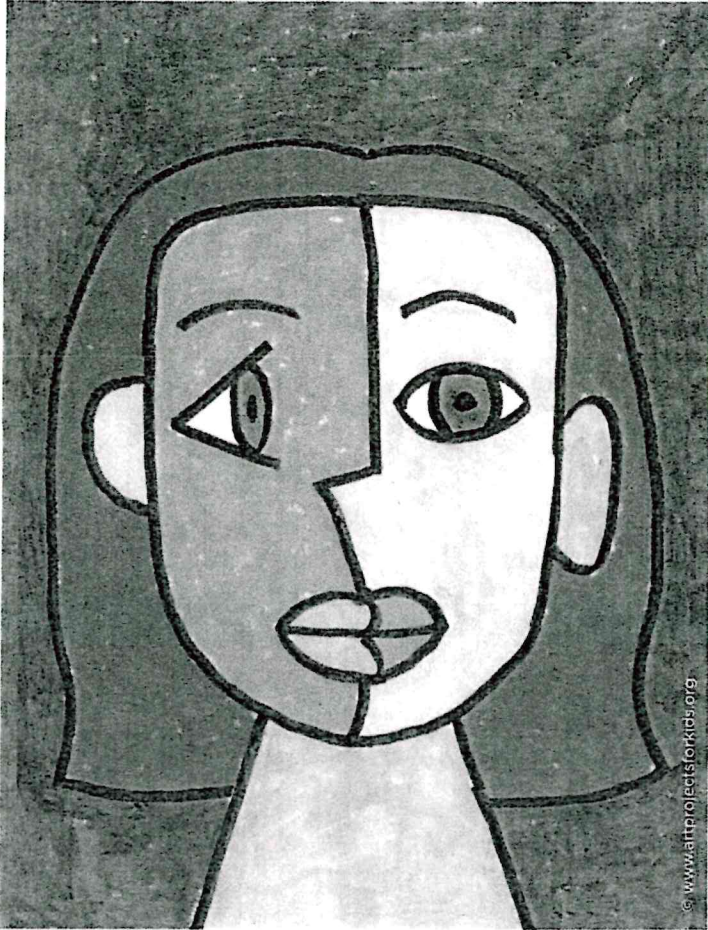

### MATERIALS

- White drawing paper
- Black permanent marker, chisel tip
- Crayons or markers  
(I used Creativity Street Glide-On Tempera Color Sticks)

Cubism is a style of painting that was developed in the early 1900s, and shows objects from many angles at once. Two main artists, Pablo Picasso and Georges Braque, developed Cubism. They believed that painters should not just present realistic views of subjects. Instead, they wanted to show every part of the whole subject.

Students can follow this simple tutorial to draw a face that half profile and half front view. It's a fun way to draw a literal interpretation of the word "cubism".

### NATIONAL ARTS STANDARDS

VA:Cr1.2.2a Make art or design with various materials and tools to explore personal interests, questions, and curiosity.

### DIRECTIONS

PREP: Print template guide on page 61 for each student.

- Students follow the tutorial to draw a simple cubism style face, with their own hair added. The emphasis is on keeping the drawing very simple. No fancy eyes or clothes are needed.
- The drawing is traced with a thick black marker.
- The drawing is colored with markers or crayons or pastels. The goal is to use unusual colors - the brighter and bolder, the better!

Activity 1



# Cubism SELF PORTRAIT TUTORIAL

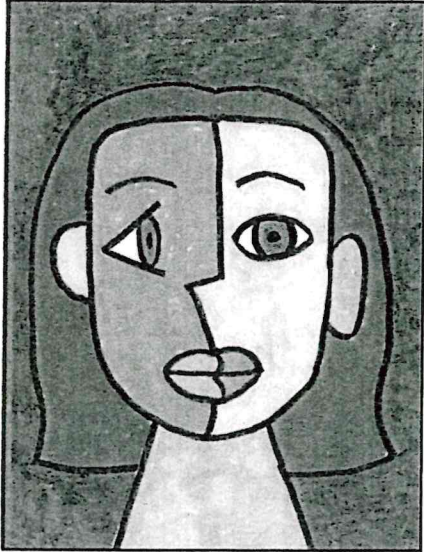

Supplies: Markers and or oil pastels

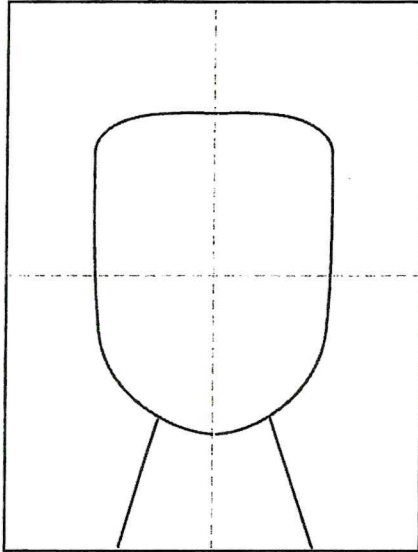

1. Fold for guide lines. Draw head and neck.

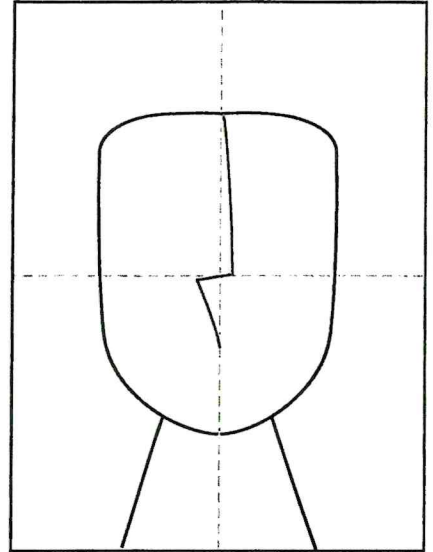

2. Start the profile nose.

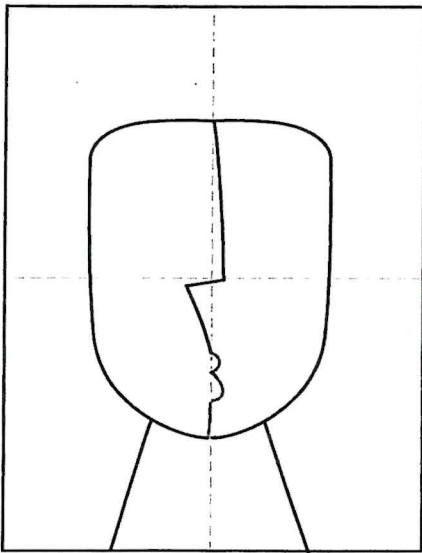

3. Add the profile mouth and chin.

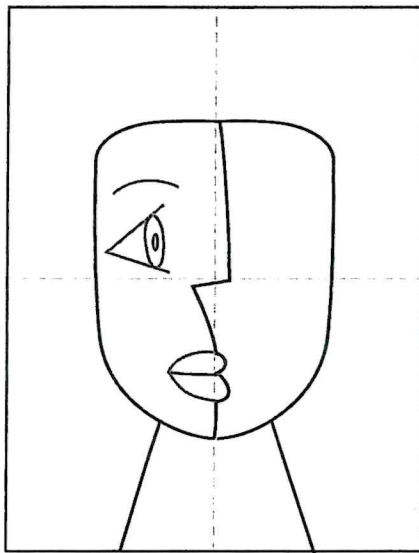

4. Draw the left profile face.

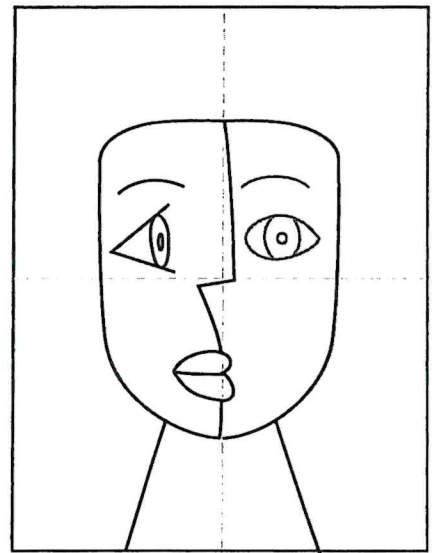

5. Draw direct looking right eye.

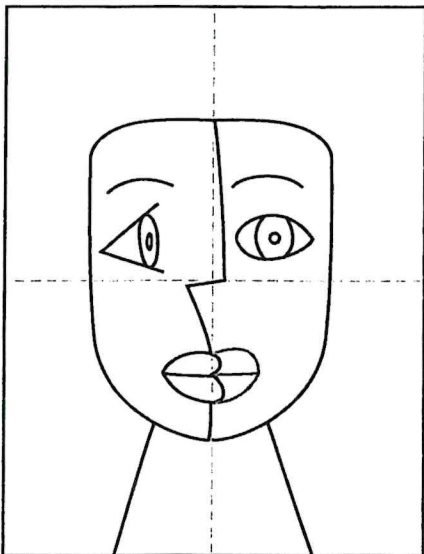

6. Add right lips.

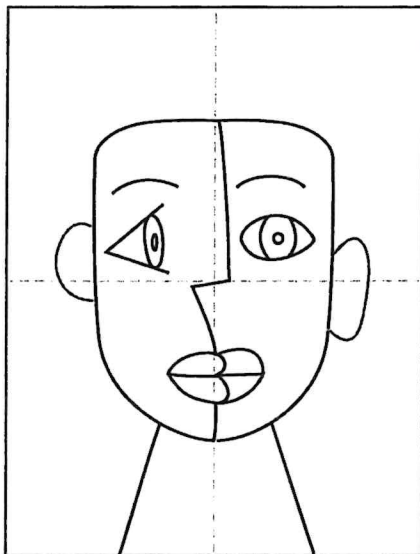

7. Add two ears, they needn't match.

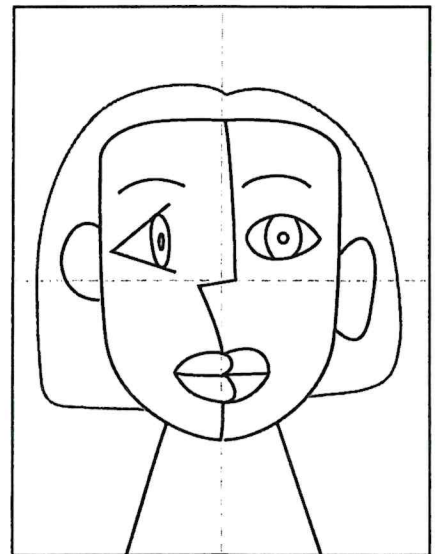

8. Finish with hair. Trace and color.







# AMI - Computer Lab

[tpatterson@seymourschool.net](mailto:tpatterson@seymourschool.net)

Office Hours: 10:00am - 2:00pm Tuesday-Friday

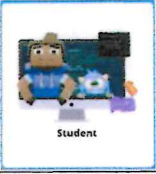
Please spend 15 minutes each AMI day in one of these programs

Grades 2 - 5	
Typesy	<p><a href="https://typesy.com/type/">typesy.com/type/</a> Username and password are the same as your AR username and password.</p>
Tynker	<p><a href="https://tynker.com">tynker.com</a></p>  
ABCya	<p><a href="https://Abcya.com">Abcya.com</a> Login: Username: clab Password: tigers</p>

Grade 1	
TypeTastic	<p><a href="https://Seymour.typetastic.com/login">Seymour.typetastic.com/login</a> Email me for login information if student cannot remember what it is.</p>
Tynker	<p><a href="https://tynker.com">tynker.com</a></p>  
ABCya	<p><a href="https://Abcya.com">Abcya.com</a> Login: Username: clab Password: tigers</p>

Kindergarten	
My Math & My Reading Academy	See attached Getting Started Guide





# AMI Day 1

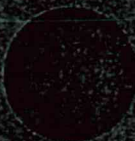

Physical Education (PE)

Coach Hosiner

Email: [phosiner@seymourschool.net](mailto:phosiner@seymourschool.net) (preferred method of communication)

Phone Number: 417-259-9607

I will be available from 8:00am to 12:00pm to answer questions.

If you message me outside of the times above I will try my best to answer within an hour.

Thank you and enjoy the exercises and activities planned for today!



# AMRAP DIRECTIONS

1. Start at the top exercise
2. Perform the exercise for the designated rep count
3. Go to the next exercise on the round arrow
4. Perform that exercise for the designated rep count
5. Continue around the arrow until all the exercises are complete
6. Repeat the AMRAP exercises if you complete the entire round
7. Perform each AMRAP visual for **5 minutes**

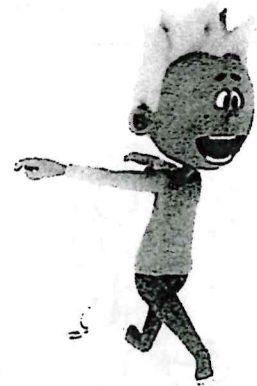

PE AMI-Day 1



# AMRAP

(AS MANY ROUNDS AS POSSIBLE)

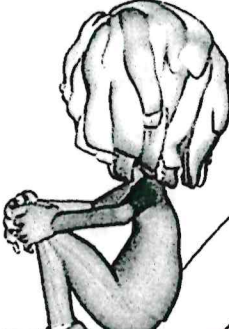

20 TUCK JUMPS

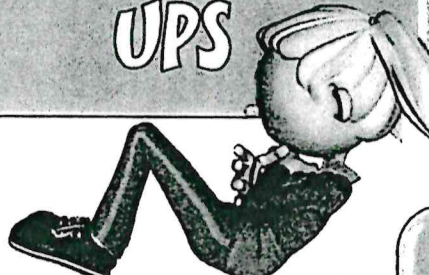

10 SIT UPS



JOG 3 LAPS

R  
E  
P  
E  
A  
T

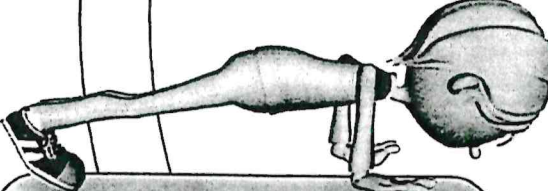

8 PUSH UPS



15 MOUNTAIN CLIMBERS



8 BURPEES

PE AMI-Day 1



# Day 2

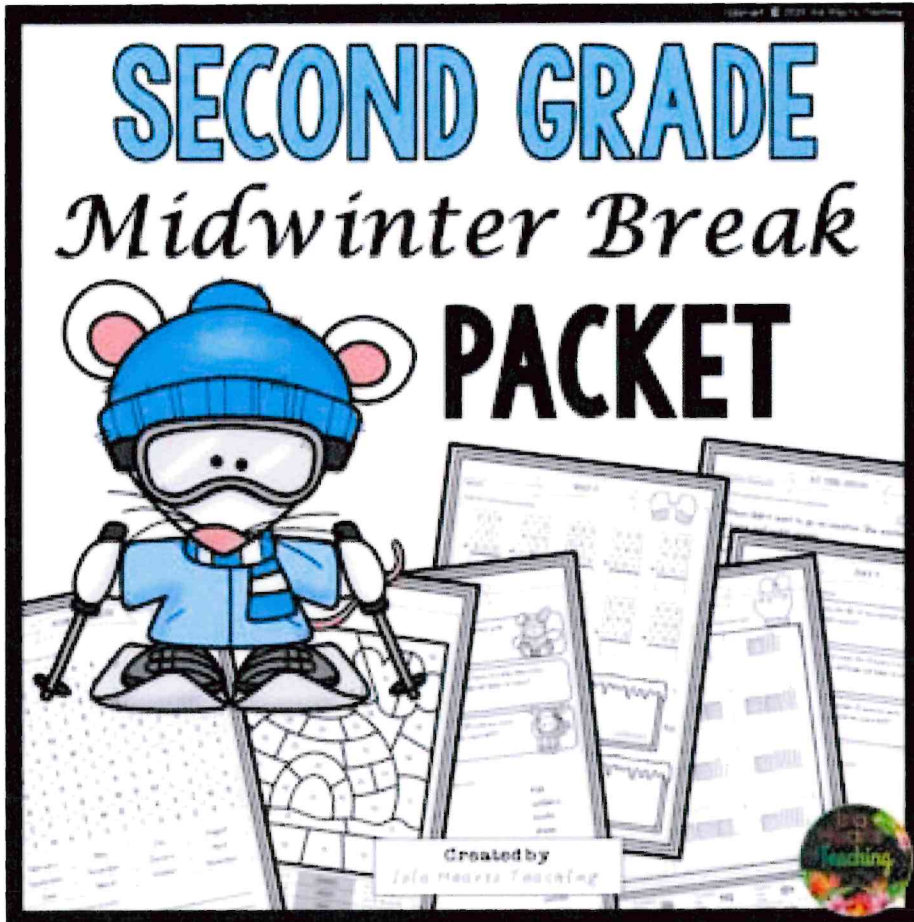

# 2<sup>nd</sup> Grade





Name \_\_\_\_\_

9



Manny the tiger was laying on the floor. The baby tigers were playing. Manny told the baby tigers to lie down and rest. The baby tigers kept playing. Manny got mad and told them again to lie down and rest.

Color the circle and then find the answer in the passage.  
Highlight the answer or the clue using the same color crayon.

1.  What was Manny doing?

2.  What were the baby tigers doing?

3.  What did Manny tell the baby tigers to do?

4.  Why did Manny get mad at the baby tigers?

5.  Do you think the little tigers did what Manny said? Why?



Name \_\_\_\_\_

# Mental Math : Using Doubles to Help Add

Directions: Use doubles to help you add.

The first two have been done for you.

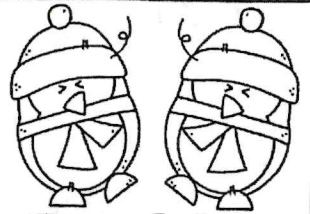

## Doubles

$1+1= \underline{\quad}$

$2+2= \underline{\quad}$

$3+3= \underline{\quad}$

$4+4= \underline{\quad}$

$5+5= \underline{\quad}$

$6+6= \underline{\quad}$

$7+7= \underline{\quad}$

$8+8= \underline{\quad}$

$9+9= \underline{\quad}$

$5+7=$

$\underline{5} + \underline{5} + \underline{2} = \underline{12}$

$9+8=$

$\underline{8} + \underline{8} + \underline{1} = \underline{17}$

$7+9=$

$\underline{\quad} + \underline{\quad} + \underline{\quad} = \underline{\quad}$

$11+9=$

$\underline{\quad} + \underline{\quad} + \underline{\quad} = \underline{\quad}$

$6+8=$

$\underline{\quad} + \underline{\quad} + \underline{\quad} = \underline{\quad}$

$6+7=$

$\underline{\quad} + \underline{\quad} + \underline{\quad} = \underline{\quad}$

$7+9=$

$\underline{\quad} + \underline{\quad} + \underline{\quad} = \underline{\quad}$

$9+8=$

$\underline{\quad} + \underline{\quad} + \underline{\quad} = \underline{\quad}$

$4+7=$

$\underline{\quad} + \underline{\quad} + \underline{\quad} = \underline{\quad}$

$9+12=$

$\underline{\quad} + \underline{\quad} + \underline{\quad} = \underline{\quad}$

$5+6=$

$\underline{\quad} + \underline{\quad} + \underline{\quad} = \underline{\quad}$

$8+5=$

$\underline{\quad} + \underline{\quad} + \underline{\quad} = \underline{\quad}$

$9+12=$

$\underline{\quad} + \underline{\quad} + \underline{\quad} = \underline{\quad}$

$7+4=$

$\underline{\quad} + \underline{\quad} + \underline{\quad} = \underline{\quad}$

$6+9=$

$\underline{\quad} + \underline{\quad} + \underline{\quad} = \underline{\quad}$

$9+5=$

$\underline{\quad} + \underline{\quad} + \underline{\quad} = \underline{\quad}$

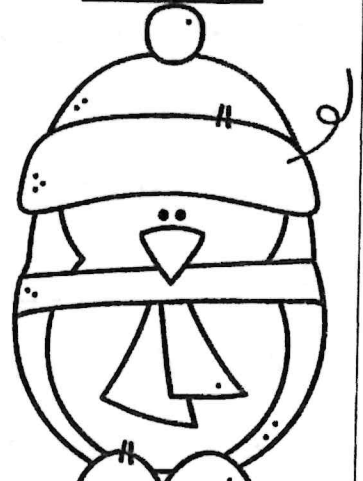
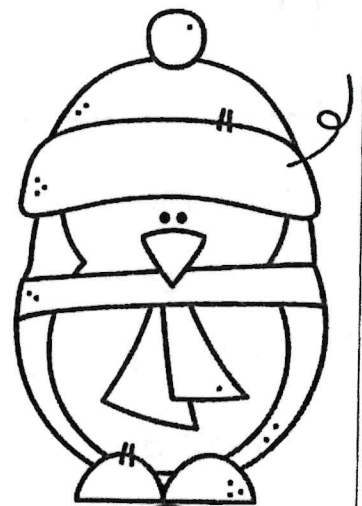



Name \_\_\_\_\_

ew ue ui

# Long u Sounds

Directions: Look at the pictures in the box. Each word has either an -ew, ue and ui. Fill in the sound boxes for each picture and write the word in the correct column.

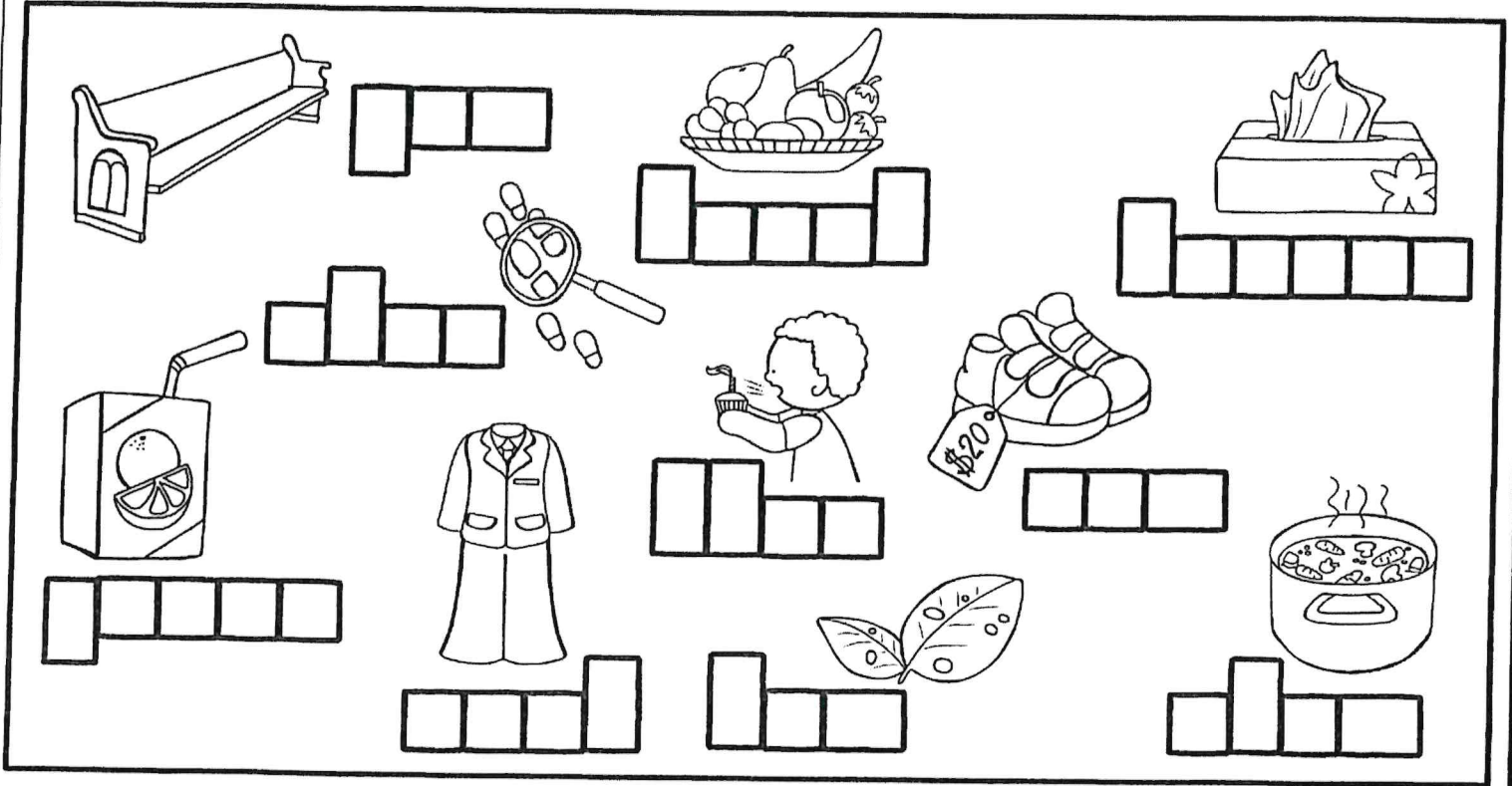

1. My mom made a pot of \_\_\_\_\_ for dinner.
2. I need a \_\_\_\_\_ for my nose.
3. We sat in the long \_\_\_\_\_.
4. I got a \_\_\_\_\_ pair of shoes at the mall today.
5. I like to drink orange \_\_\_\_\_ in the morning.
6. A piece of \_\_\_\_\_ is a healthy snack.
7. The detective is looking for a \_\_\_\_\_ to the mystery.
8. I \_\_\_\_\_ out the candle on my birthday cake.
9. My dad got a new \_\_\_\_\_ for work.
10. Early in the morning, there are droplets of \_\_\_\_\_ on the leaves.

Name: \_\_\_\_\_

# George Washington Timeline

Directions: Cut and paste each event under the correct time.

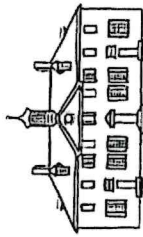

1732

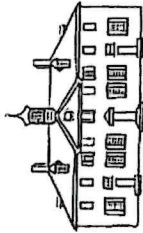

1759

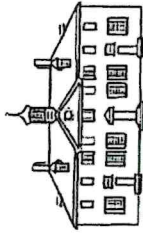

1775

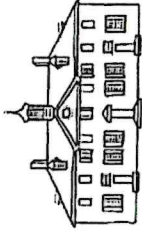

1789

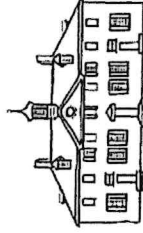

1799

He dies at his home.

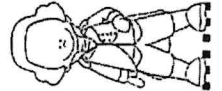

The Revolutionary War began.

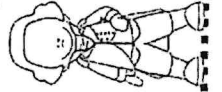

He was elected president.

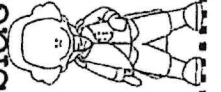

George Washington was born.

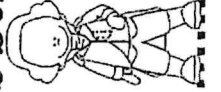

He married Martha Custis.

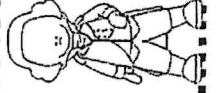





## ART AMI ACTIVITIES 1&2



Mrs. Dean

E-mail: [adean@seymourschool.net](mailto:adean@seymourschool.net) (preferred method of communication)

Phone: 417-207-3844

I will be available for contact from 9 a.m. to 1 p.m.

(If messaged outside time above I will try to respond within an hour)

When completing Art activities feel free to use whatever materials you have available.





# Vasarely Color Project

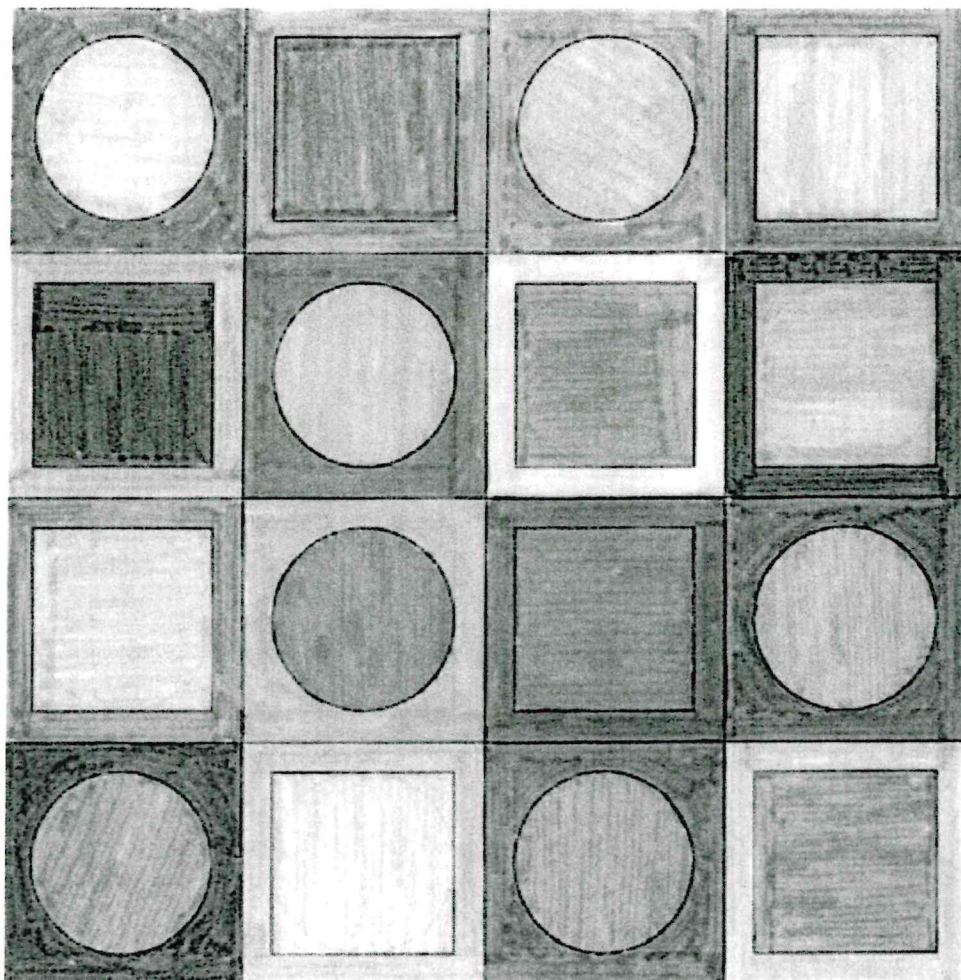

Victor Vasarely (1906-1997) was a Hungarian-French artist who became one of the leading figures of the Op art movement. Through the use of precise and abstract shapes, his art had a quality that is not seen in other styles of art.

## GOAL

Students use lines to trace abstract shapes in the style of Victor Vasarely. The circles and squares are colored in a way to learn more about warm and cool colors.

## ELEMENTS OF ART

Line, Shape, Value, Color

## MATERIALS

- Drawing paper
- Black marker
- Markers

## DIRECTIONS

1. Print a template. Choose a random group of circles to trace.
2. Trace squares in the remaining spaces.
3. Color the inside four squares with warm or cool colors.
4. Fill in the remaining squares with warm or cool colors.

Activity 2



# Vasarely Color Project

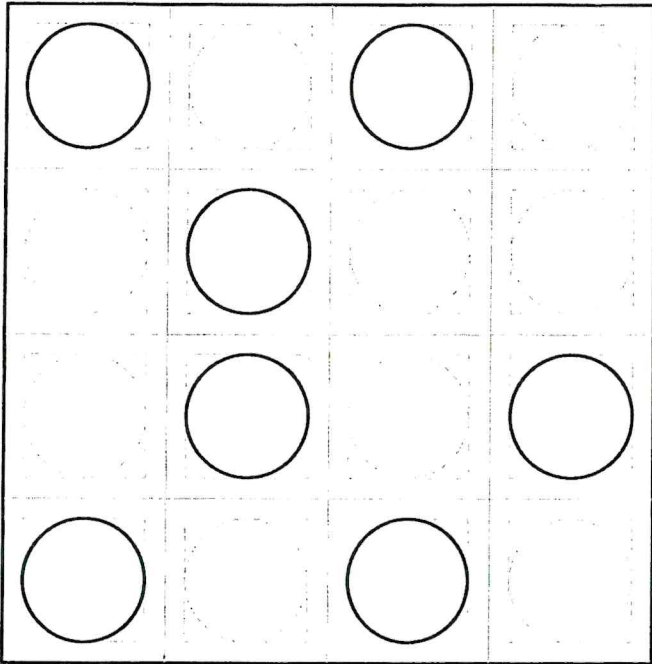

1. Print a template. Choose a random group of circles to trace.

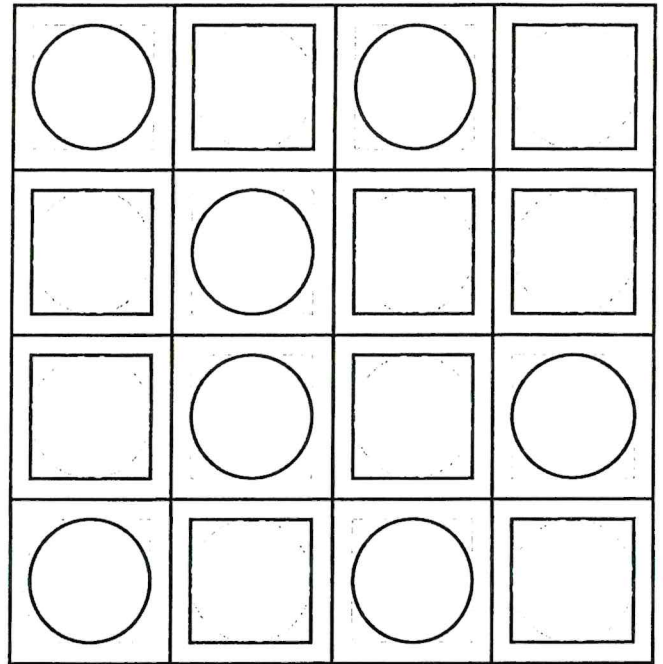

2. Trace squares in the remaining spaces.

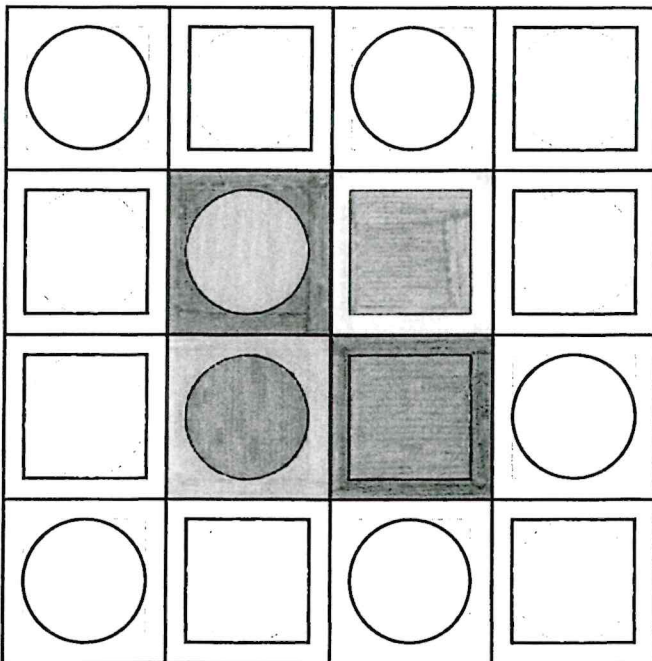

3. Color the inside four squares with warm or cool colors.

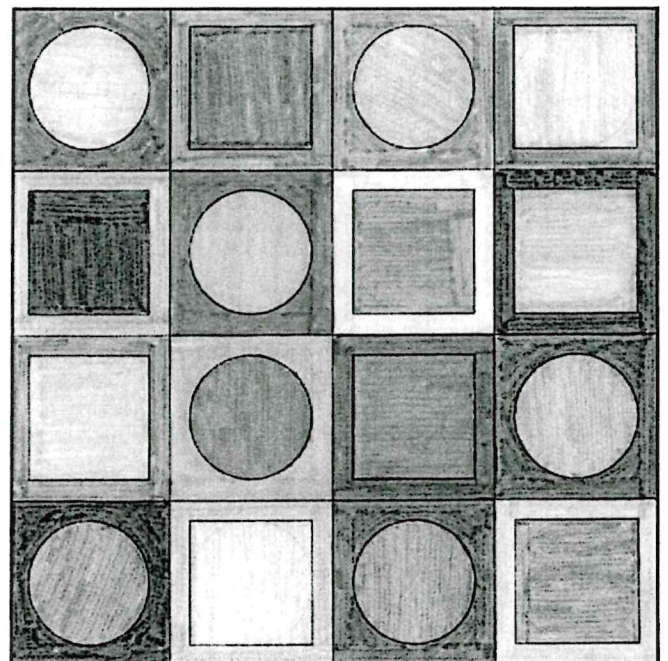

4. Fill in the remaining squares with warm or cool colors.



# Vasarely Template

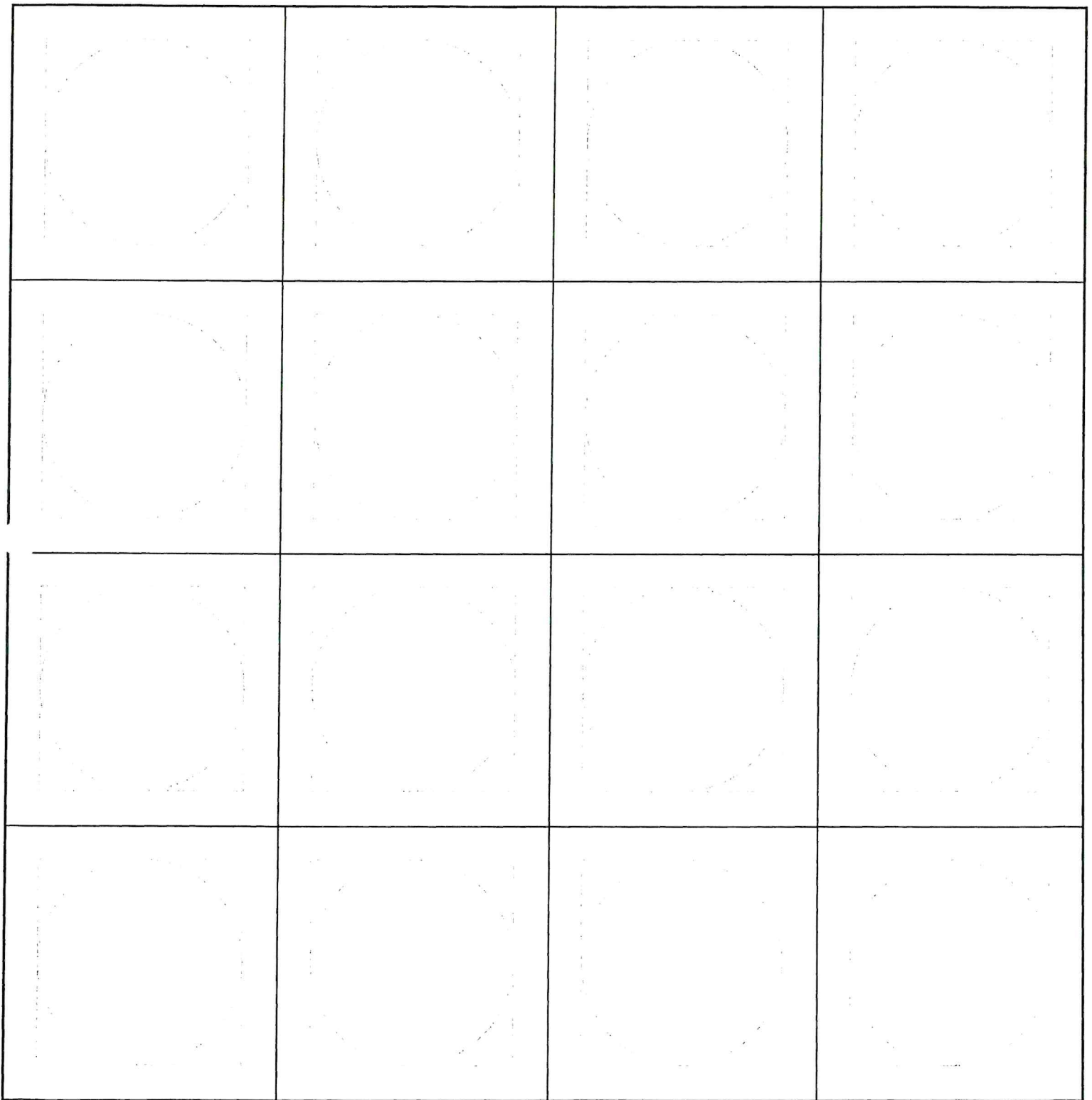







# AMI - Computer Lab

[tpatterson@seymourschool.net](mailto:tpatterson@seymourschool.net)

Office Hours: 10:00am - 2:00pm Tuesday-Friday

Please spend 15 minutes each AMI day in one of these programs

## Grades 2 - 5

Typesy	typesy.com/type/ Username and password are the same as your AR username and password.
Tynker	tynker.com  
ABCya	Abcya.com Login: Username: clab Password: tigers

## Grade 1

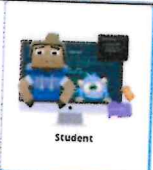
TypeTastic	Seymour.typetastic.com/login Email me for login information if student cannot remember what it is.
Tynker	tynker.com  
ABCya	Abcya.com Login: Username: clab Password: tigers

## Kindergarten

My Math & My Reading Academy	See attached Getting Started Guide
------------------------------	------------------------------------



# Music AMI Day 2

Teacher: Mrs. Rechtfertig



Email: [arechtfertig@seymourschool.net](mailto:arechtfertig@seymourschool.net)  
Office hours: 9am-1pm



Name: \_\_\_\_\_

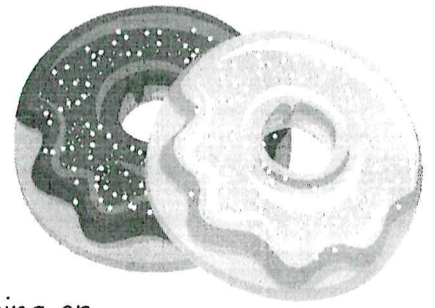

In music, there are symbols that tell you how loud or quiet to sing or play. This list shows you the symbol, what it is called, and what it means.

<b><i>ppp</i></b>	Pianississimo	Very, Very Quiet
<b><i>pp</i></b>	Pianissimo	Very Quiet
<b><i>p</i></b>	Piano	Quiet
<b><i>mp</i></b>	Mezzo Piano	Medium Quiet
<b><i>mf</i></b>	Mezzo Forte	Medium Loud
<b><i>f</i></b>	Forte	Loud
<b><i>ff</i></b>	Fortissimo	Very Loud
<b><i>fff</i></b>	Fortississimo	Very, Very Loud

Name: \_\_\_\_\_



Directions: Add frosting to (color in) the donut in each box that contains the dynamic that is LOUDER.



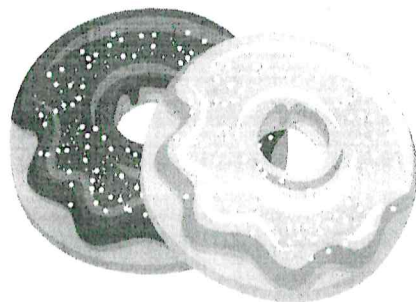

Name: \_\_\_\_\_



Directions: Add frosting to (color in) the donut in each box that contains the dynamic that is QUIETER.

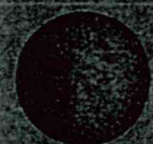

# AMI Day 2



Physical Education (PE)

Coach Hosiner

Email: [phosiner@seymourschool.net](mailto:phosiner@seymourschool.net) (preferred method of communication)

Phone Number: 417-259-9607

I will be available from 8:00am to 12:00pm to answer questions.

If you message me outside of the times above I will try my best to answer within an hour.

Thank you and enjoy the exercises and activities planned for today!





# SKILL FOCUS DIRECTIONS

**Equipment:** *Rolled up socks or beanbags*

**Space:** *Small area inside or outside*

**Safety:** *Don't toss too high...watch your ceilings*



1. Start with the number 1 skill.
2. Perform the skill for the designated time suggested.
3. Go to the next skill challenge.
4. Perform that skill for the designated time suggested.
5. Continue through all 6 skill challenges (12 minutes).
6. If you have time, try the challenges you like best again.





# 2 HAND CATCH

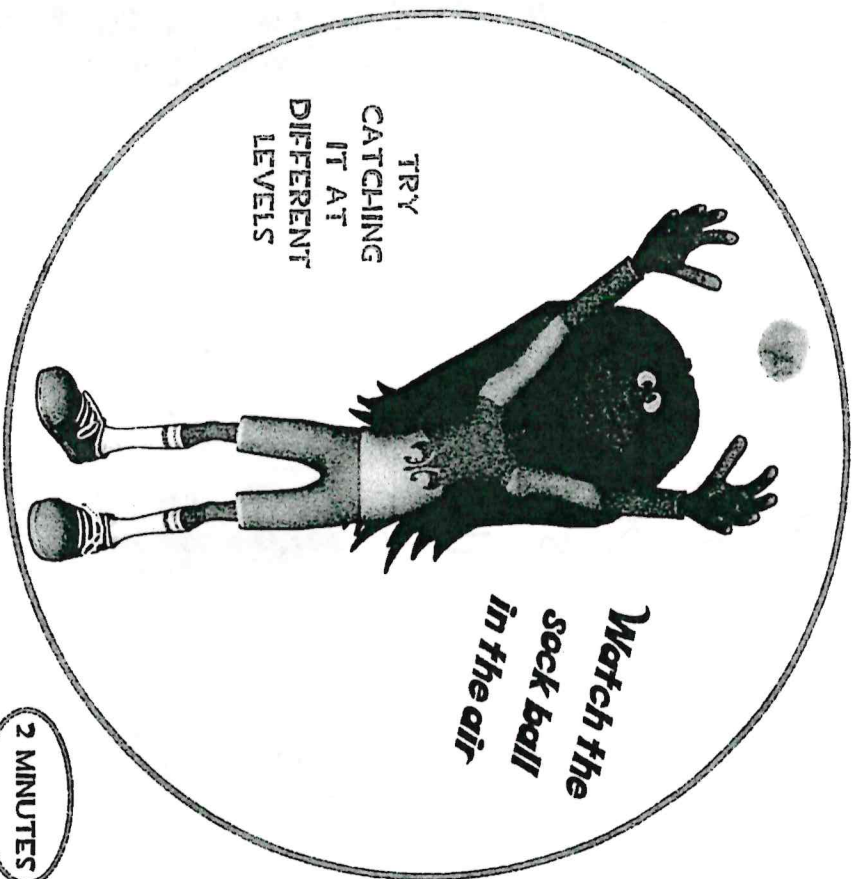

Toss the sock ball up in the air with 1 hand and catch it in front of your body using 2 hands.

1

CATCHING

# 1 HAND CATCH



Toss the sock ball up in the air with 1 or 2 hands and catch it in front of your body using only 1 hand.

2

CATCHING

PE AMI-  
Day 1

# RAINBOW TOSS

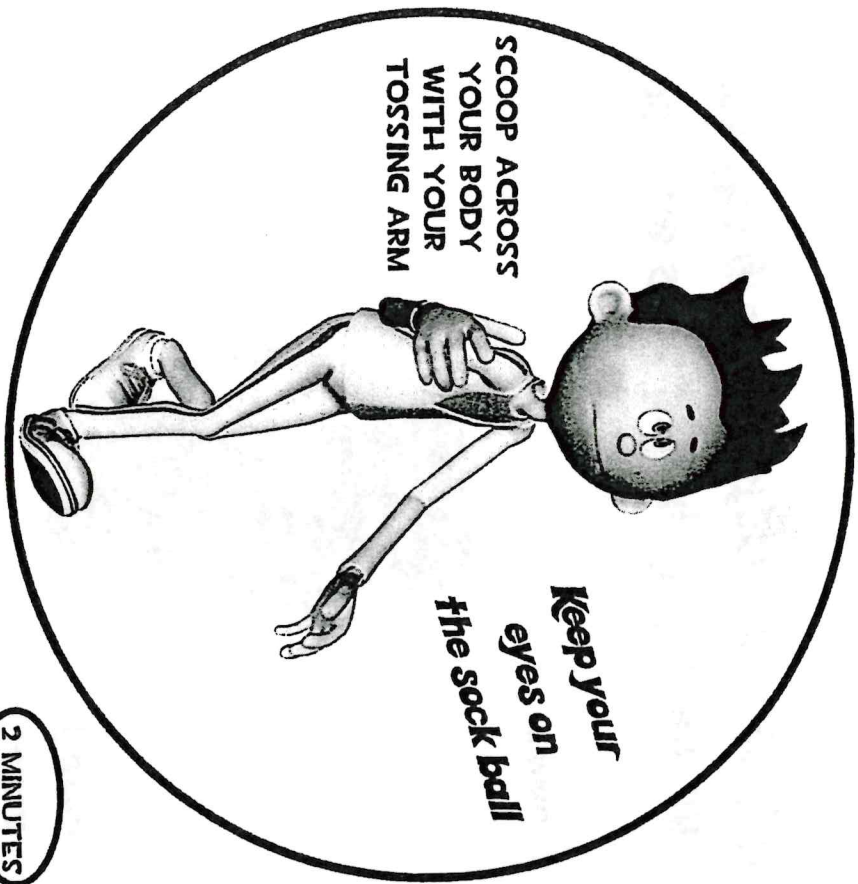

SCOOP ACROSS  
YOUR BODY  
WITH YOUR  
TOSSING ARM

*Keep your  
eyes on  
the sock ball*

2 MINUTES

Toss the sock ball across your body from 1 hand to the other. The sock ball should travel in a rainbow shape.

3

CATCHING

# TOSS/CLAP/CATCH

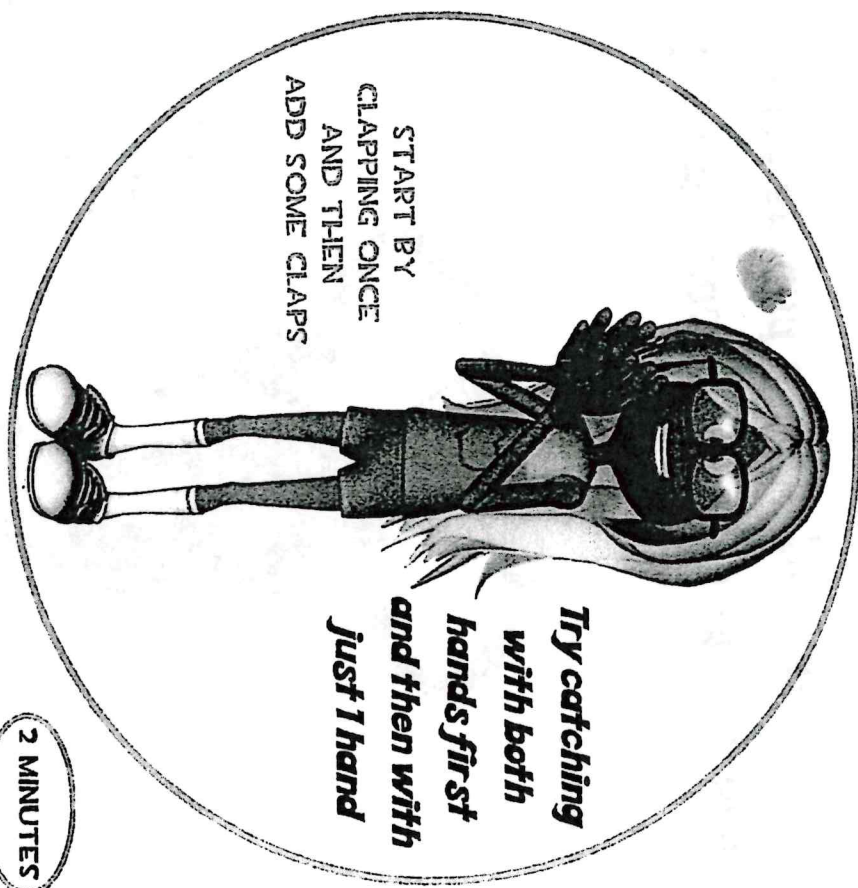

START BY  
CLAPPING ONCE  
AND THEN  
ADD SOME CLAPS

*Try catching  
with both  
hands first  
and then with  
just 1 hand*

2 MINUTES

Toss the sock ball up in the air and clap once or a few times before you catch it.

4

CATCHING

PE AMI  
Day 1



# TOSS/TOUCH/CATCH

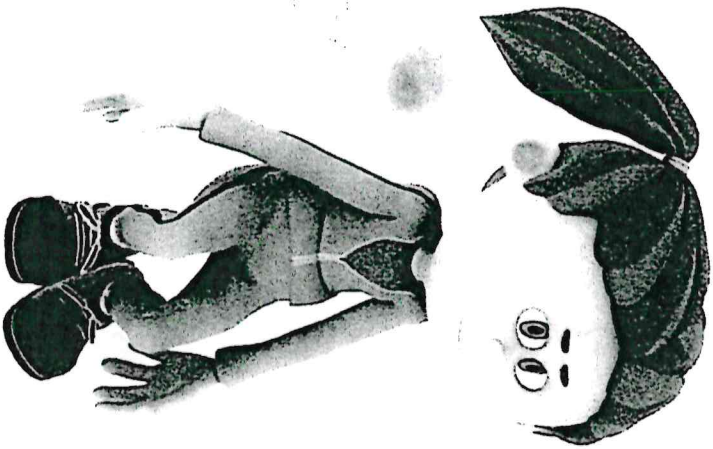

**Toss**  
**Touch**  
**Catch**

2 MINUTES

Toss the sock ball up in the air and touch the ground before you catch it.

5

CATCHING

# TOSS/TURN/CATCH

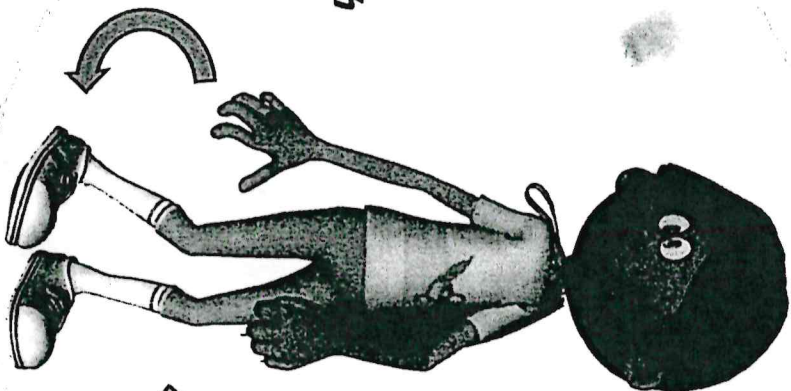

**Toss**  
**Turn**  
**Catch**

TRY TO TURN  
ALL THE  
WAY AROUND

2 MINUTES

Toss the sock ball up in the air and turn around before you catch it.

6

CATCHING

PE AM'S  
Day 1

# Day 3

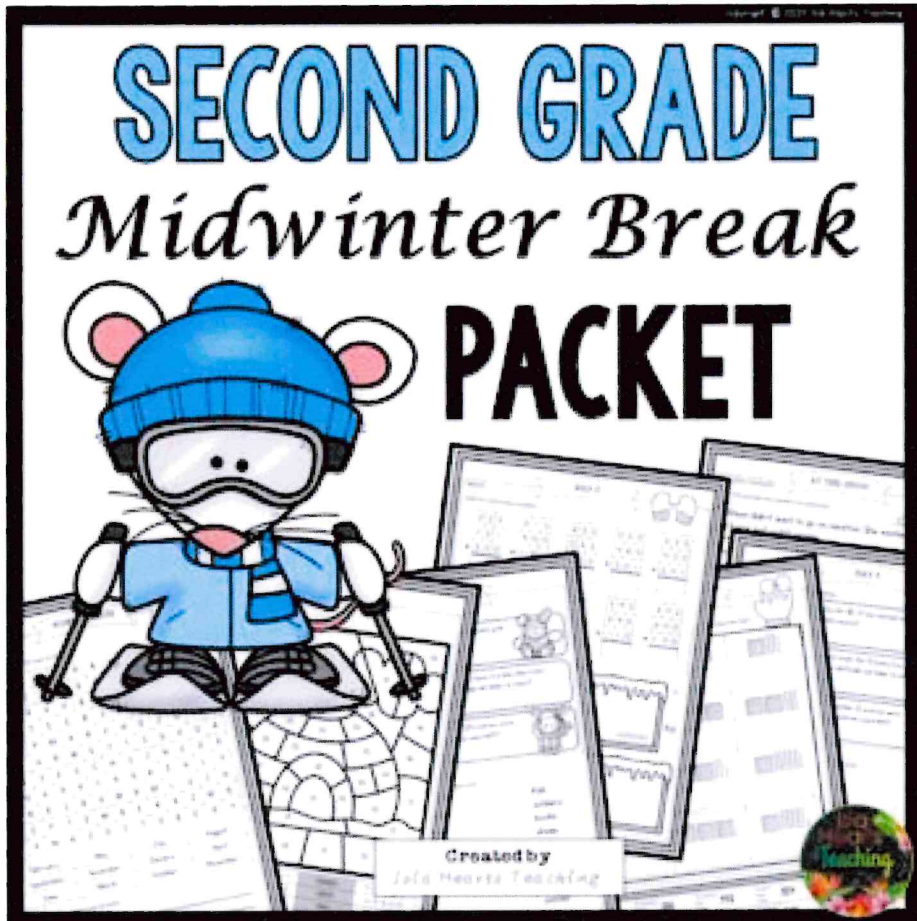

# 2<sup>nd</sup> Grade







The five dogs were barking and barking. Kelly told them to stop. They did not stop. Kelly called each dog's name and said stop. Then Kelly gave the dogs food when they stopped barking.

Color the circle and then find the answer in the passage. Highlight the answer or the clue using the same color crayon.

1.  How many dogs were there?

---

---

---

2.  What did Kelly tell them?

---

---

---

3.  Did they stop at first?

---

---

---

4.  What did Kelly do next to make them stop?

---

---

---

5.  What did Kelly give the dogs at the end?

---

---

---

Name \_\_\_\_\_

# Supporting Details I

Directions: Read the topic sentence.

Use the picture to help you write supporting details that relate to the topic sentence.

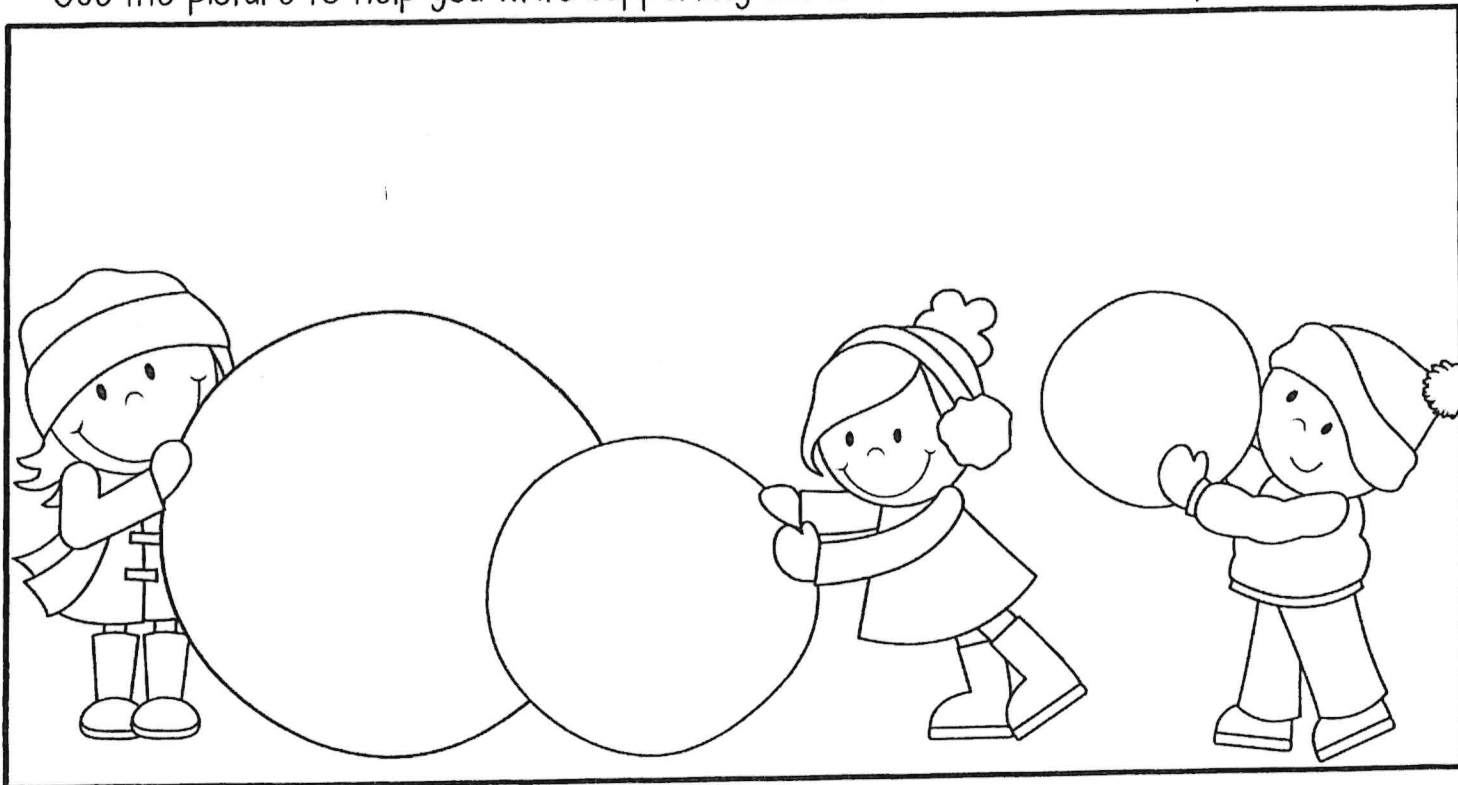

Building a snowman is a lot of work.

---

---

---

---

---

---

---

---

---

---

Name \_\_\_\_\_

# Roll and Solve Addition with Regrouping

Directions: Roll a die and solve a math problem in that column.  
Continue playing (by yourself or with a partner) until all problems have been solved.



$\begin{array}{r} 67 \\ + 84 \\ \hline \end{array}$	$\begin{array}{r} 74 \\ + 49 \\ \hline \end{array}$	$\begin{array}{r} 33 \\ + 98 \\ \hline \end{array}$	$\begin{array}{r} 51 \\ + 79 \\ \hline \end{array}$	$\begin{array}{r} 34 \\ + 89 \\ \hline \end{array}$	$\begin{array}{r} 21 \\ + 99 \\ \hline \end{array}$
$\begin{array}{r} 77 \\ + 74 \\ \hline \end{array}$	$\begin{array}{r} 42 \\ + 78 \\ \hline \end{array}$	$\begin{array}{r} 91 \\ + 79 \\ \hline \end{array}$	$\begin{array}{r} 81 \\ + 39 \\ \hline \end{array}$	$\begin{array}{r} 36 \\ + 86 \\ \hline \end{array}$	$\begin{array}{r} 38 \\ + 95 \\ \hline \end{array}$
$\begin{array}{r} 31 \\ + 89 \\ \hline \end{array}$	$\begin{array}{r} 54 \\ + 79 \\ \hline \end{array}$	$\begin{array}{r} 77 \\ + 17 \\ \hline \end{array}$	$\begin{array}{r} 55 \\ + 27 \\ \hline \end{array}$	$\begin{array}{r} 44 \\ + 49 \\ \hline \end{array}$	$\begin{array}{r} 56 \\ + 26 \\ \hline \end{array}$
$\begin{array}{r} 65 \\ + 18 \\ \hline \end{array}$	$\begin{array}{r} 24 \\ + 29 \\ \hline \end{array}$	$\begin{array}{r} 21 \\ + 59 \\ \hline \end{array}$	$\begin{array}{r} 29 \\ + 33 \\ \hline \end{array}$	$\begin{array}{r} 35 \\ + 47 \\ \hline \end{array}$	$\begin{array}{r} 29 \\ + 25 \\ \hline \end{array}$
$\begin{array}{r} 17 \\ + 18 \\ \hline \end{array}$	$\begin{array}{r} 76 \\ + 14 \\ \hline \end{array}$	$\begin{array}{r} 35 \\ + 47 \\ \hline \end{array}$	$\begin{array}{r} 49 \\ + 22 \\ \hline \end{array}$	$\begin{array}{r} 34 \\ + 39 \\ \hline \end{array}$	$\begin{array}{r} 27 \\ + 98 \\ \hline \end{array}$
$\begin{array}{r} 69 \\ + 56 \\ \hline \end{array}$	$\begin{array}{r} 65 \\ + 79 \\ \hline \end{array}$	$\begin{array}{r} 38 \\ + 48 \\ \hline \end{array}$	$\begin{array}{r} 47 \\ + 29 \\ \hline \end{array}$	$\begin{array}{r} 56 \\ + 35 \\ \hline \end{array}$	$\begin{array}{r} 98 \\ + 78 \\ \hline \end{array}$



Name \_\_\_\_\_

# Long O Sounds

Directions: Look at the pictures in the box. Each word has either an -ow, oe, or oa. Fill in the sound boxes for each picture and write the word in the correct column.

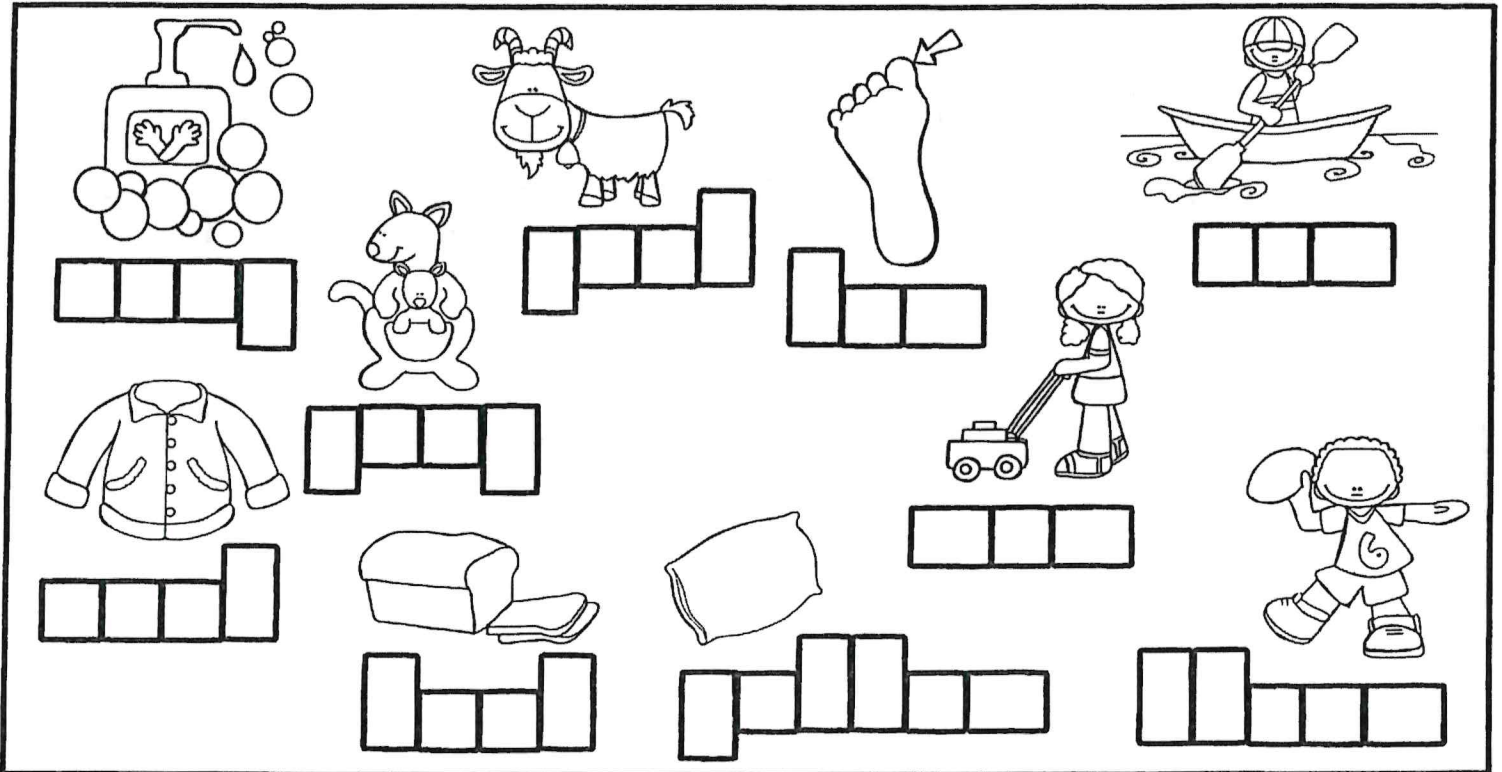
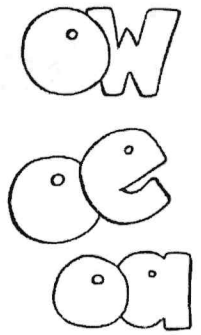

1. I use a soft \_\_\_\_\_ when I sleep.
2. I will get my \_\_\_\_\_ since it is cold outside.
3. Wash your hands with \_\_\_\_\_ and water.
4. I like to \_\_\_\_\_ my boat around the lake.
5. When the grass gets long, we need to \_\_\_\_\_ it.
6. I stubbed my big \_\_\_\_\_ today.
7. A baby kangaroo is called a \_\_\_\_\_.
8. The \_\_\_\_\_ is eating the grass.
9. My mom made a fresh \_\_\_\_\_ of bread today.
10. Can you \_\_\_\_\_ me the ball so I can catch it?



# Day 4

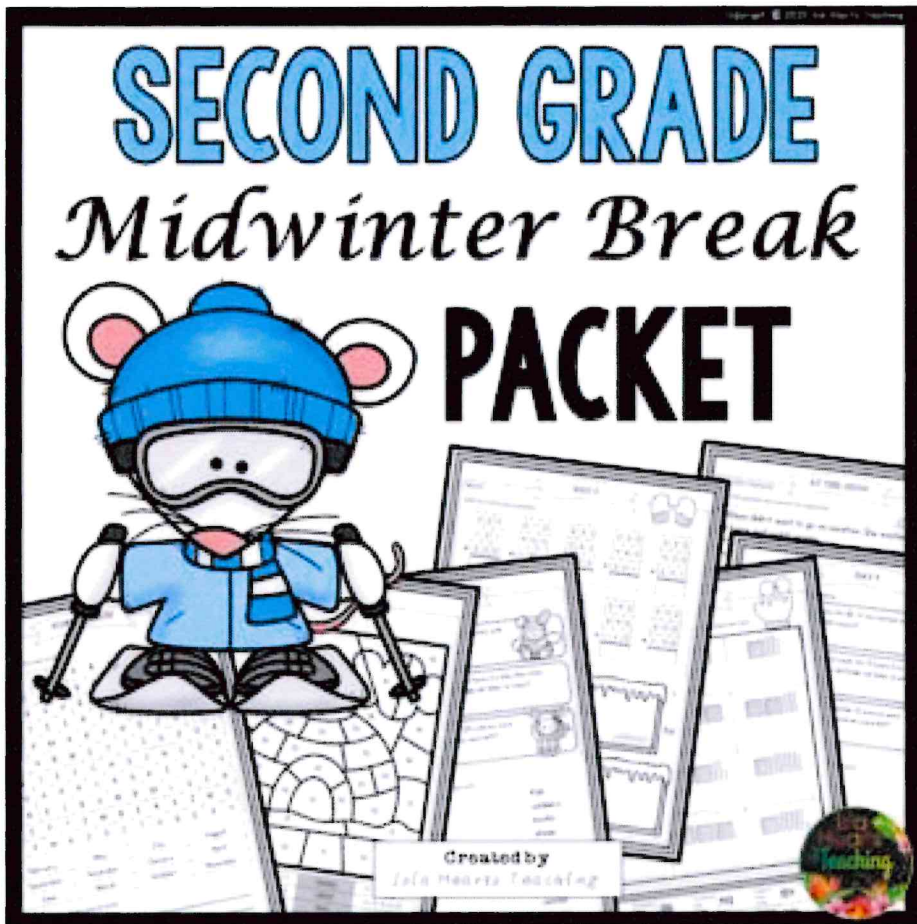

# 2<sup>nd</sup> Grade





We have to go back to school after winter break. There is my friend Donny with the pencil. Jamie has a pad of paper. Todd has a book. I am glad to go back to school.

Color the circle and then find the answer in the passage. Highlight the answer or the clue using the same color crayon.

1.  What time of year is it?

2.  What does Donny have?

3.  What does Jamie have?

4.  What does Todd have?

5.  Would you be glad to go back to school?

Name \_\_\_\_\_

ie igh  
y Sounds like

# Long i Sounds

Directions: Look at the pictures in the box. Each word has either an -ie, -ight or -y vowel sound. Spell out the words in the sound boxes and complete each sentence with the correct word.

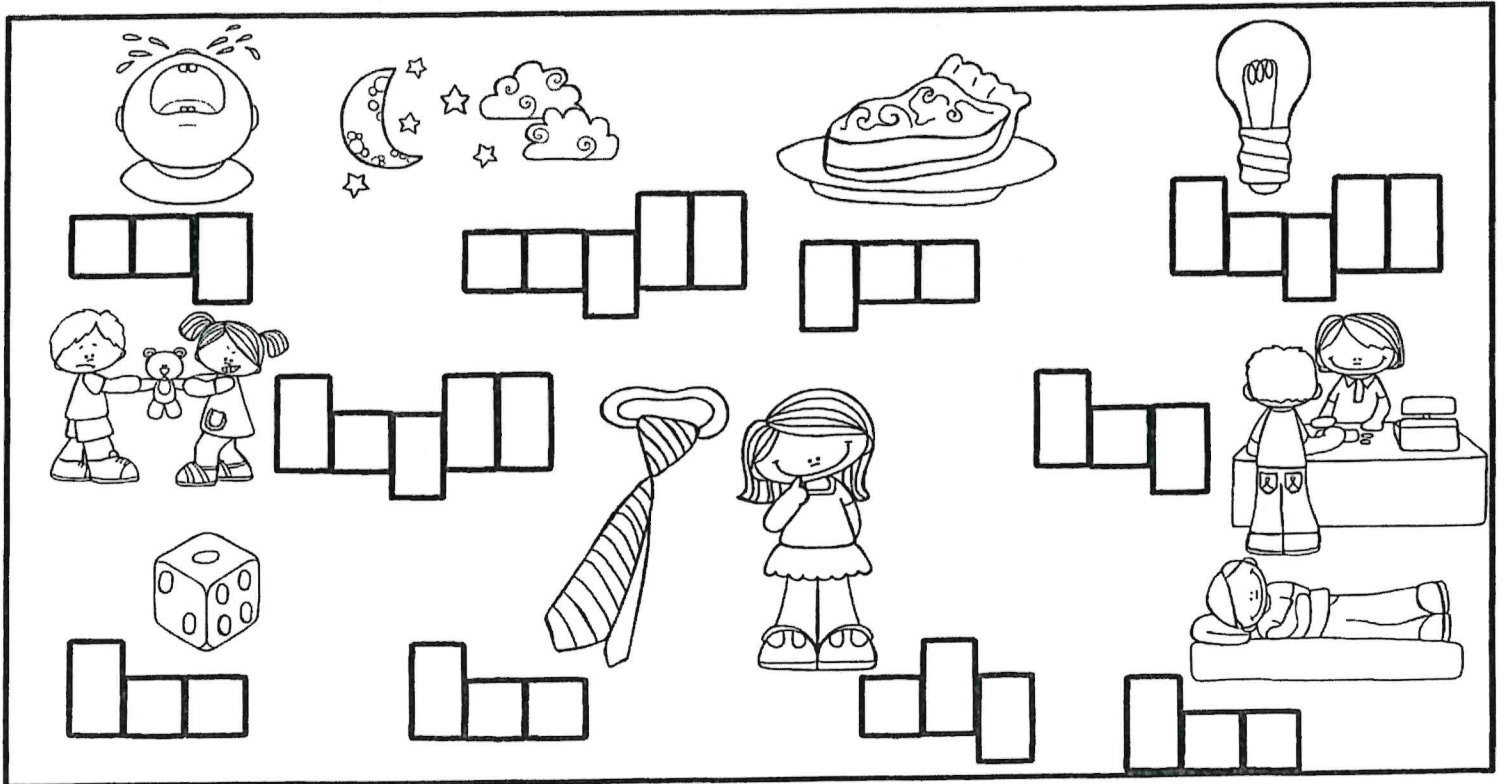

1. Please turn on the \_\_\_\_\_ so we can see.
2. It's your turn to roll the \_\_\_\_\_.
3. My favorite dessert is apple \_\_\_\_\_.
4. If you wake up the baby, she will start to \_\_\_\_\_.
5. On a clear \_\_\_\_\_, I can see the stars.
6. I get a little \_\_\_\_\_ when I meet new people.
7. We are going to the store to \_\_\_\_\_ my sister a birthday present.
8. I think I will \_\_\_\_\_ down and rest awhile.
9. Please do not \_\_\_\_\_ and argue about the toy.
10. We bought our dad a new \_\_\_\_\_ for Father's Day.



Name \_\_\_\_\_

# Supporting Details II

Directions: Read the topic sentence.

Use the picture to help you write supporting details that relate to the topic sentence.

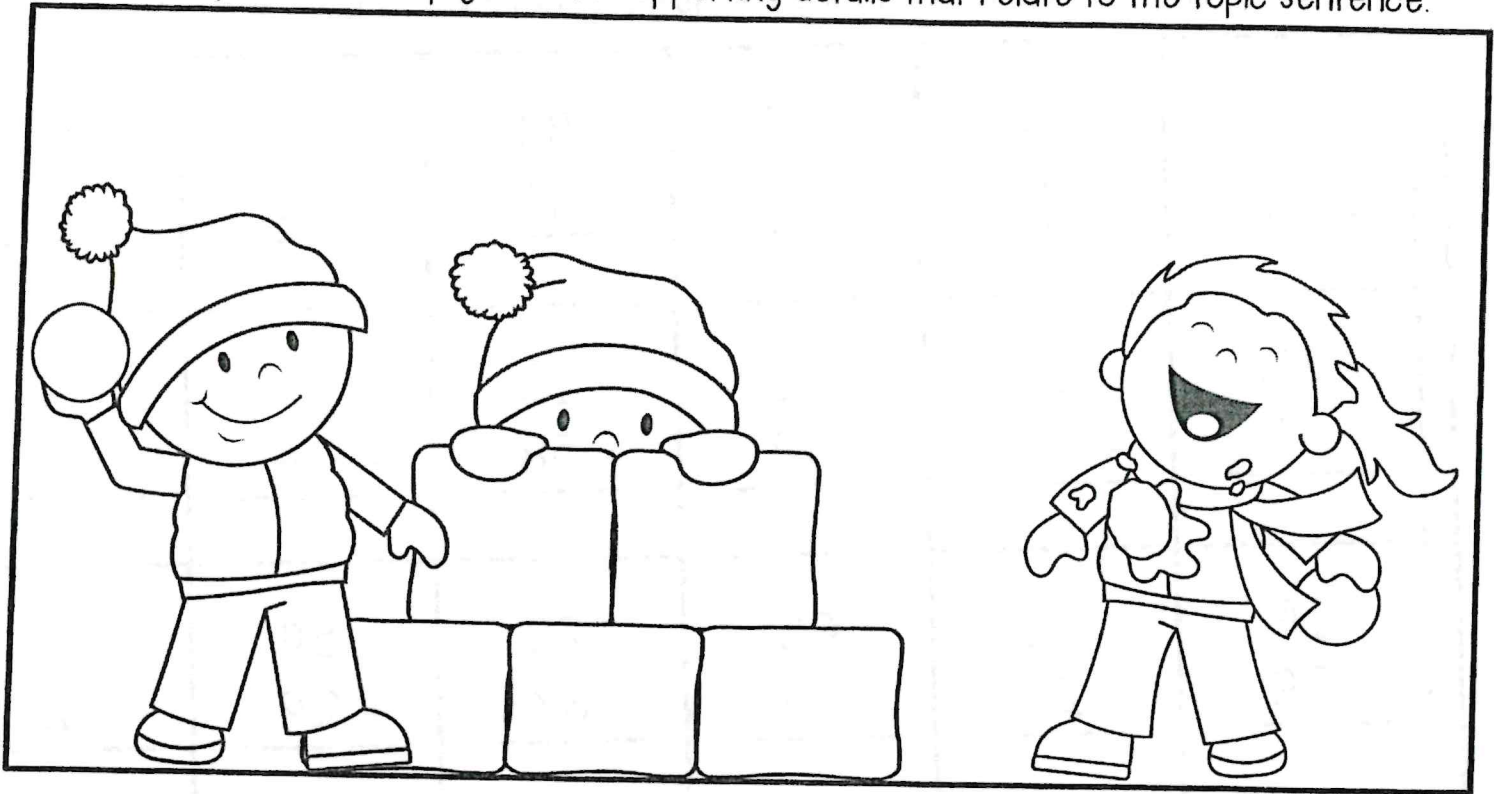

It is fun to have a snowball fight.

---

---

---

---

---

---

---

---

---

---



Name \_\_\_\_\_

# Roll and Add or Subtract with Regrouping



Directions: Roll a die and solve a math problem in that column.

Continue playing (by yourself or with a partner) until all problems have been solved.

$\begin{array}{r} 17 \\ + 44 \\ \hline \end{array}$	$\begin{array}{r} 32 \\ - 19 \\ \hline \end{array}$	$\begin{array}{r} 21 \\ + 39 \\ \hline \end{array}$	$\begin{array}{r} 94 \\ - 49 \\ \hline \end{array}$	$\begin{array}{r} 45 \\ + 27 \\ \hline \end{array}$	$\begin{array}{r} 75 \\ - 16 \\ \hline \end{array}$
$\begin{array}{r} 32 \\ - 19 \\ \hline \end{array}$	$\begin{array}{r} 54 \\ + 38 \\ \hline \end{array}$	$\begin{array}{r} 80 \\ - 18 \\ \hline \end{array}$	$\begin{array}{r} 12 \\ + 58 \\ \hline \end{array}$	$\begin{array}{r} 92 \\ - 74 \\ \hline \end{array}$	$\begin{array}{r} 14 \\ + 68 \\ \hline \end{array}$
$\begin{array}{r} 14 \\ + 29 \\ \hline \end{array}$	$\begin{array}{r} 40 \\ - 23 \\ \hline \end{array}$	$\begin{array}{r} 66 \\ + 19 \\ \hline \end{array}$	$\begin{array}{r} 70 \\ - 37 \\ \hline \end{array}$	$\begin{array}{r} 59 \\ + 29 \\ \hline \end{array}$	$\begin{array}{r} 91 \\ - 52 \\ \hline \end{array}$
$\begin{array}{r} 46 \\ - 28 \\ \hline \end{array}$	$\begin{array}{r} 71 \\ + 19 \\ \hline \end{array}$	$\begin{array}{r} 77 \\ - 28 \\ \hline \end{array}$	$\begin{array}{r} 22 \\ + 28 \\ \hline \end{array}$	$\begin{array}{r} 81 \\ - 44 \\ \hline \end{array}$	$\begin{array}{r} 48 \\ + 38 \\ \hline \end{array}$
$\begin{array}{r} 71 \\ + 19 \\ \hline \end{array}$	$\begin{array}{r} 93 \\ - 28 \\ \hline \end{array}$	$\begin{array}{r} 92 \\ + 17 \\ \hline \end{array}$	$\begin{array}{r} 86 \\ - 57 \\ \hline \end{array}$	$\begin{array}{r} 58 \\ + 17 \\ \hline \end{array}$	$\begin{array}{r} 65 \\ - 38 \\ \hline \end{array}$
$\begin{array}{r} 51 \\ - 13 \\ \hline \end{array}$	$\begin{array}{r} 69 \\ + 26 \\ \hline \end{array}$	$\begin{array}{r} 64 \\ - 48 \\ \hline \end{array}$	$\begin{array}{r} 76 \\ + 19 \\ \hline \end{array}$	$\begin{array}{r} 90 \\ - 73 \\ \hline \end{array}$	$\begin{array}{r} 64 \\ + 38 \\ \hline \end{array}$

Exploring

Winter

Using my

Senses

Name: \_\_\_\_\_  
Use your 5 senses outside to explore the season of winter.

I see \_\_\_\_\_  
\_\_\_\_\_  
\_\_\_\_\_  
\_\_\_\_\_

I hear \_\_\_\_\_  
\_\_\_\_\_  
\_\_\_\_\_  
\_\_\_\_\_

I smell \_\_\_\_\_  
\_\_\_\_\_  
\_\_\_\_\_  
\_\_\_\_\_

I touch \_\_\_\_\_  
\_\_\_\_\_  
\_\_\_\_\_  
\_\_\_\_\_

I taste \_\_\_\_\_  
\_\_\_\_\_  
\_\_\_\_\_  
\_\_\_\_\_



# Day 5

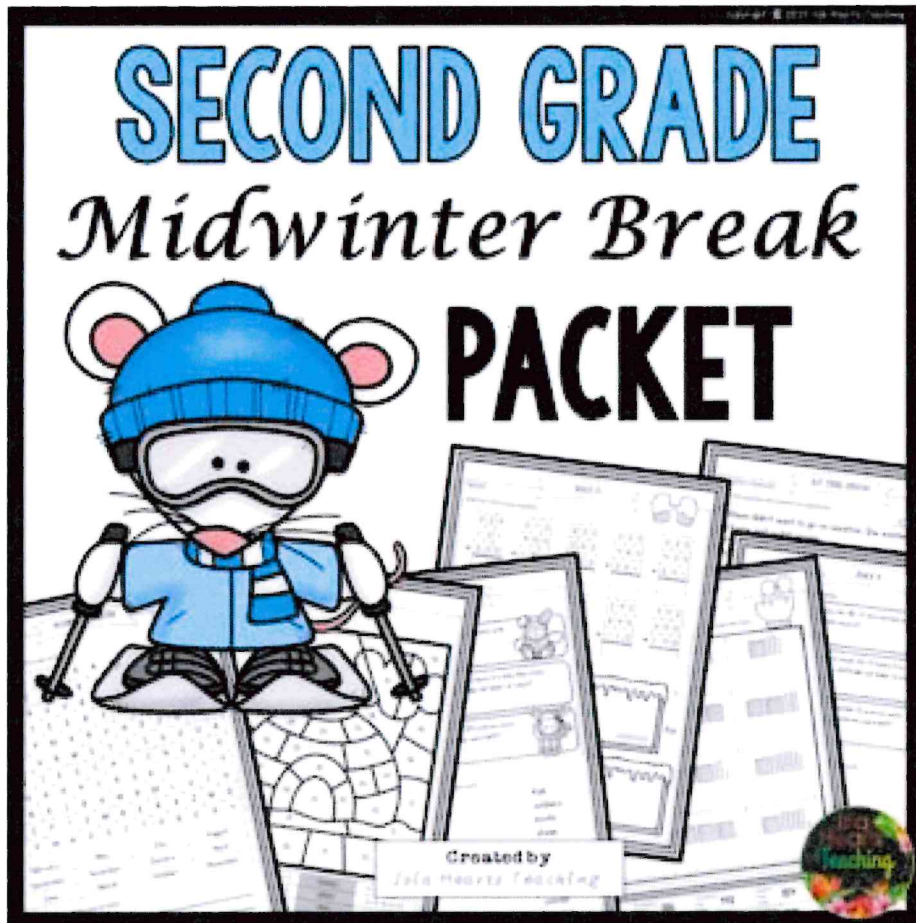

# 2<sup>nd</sup> Grade





Name \_\_\_\_\_

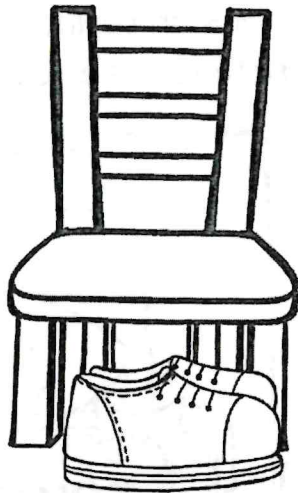

Chad lost his shoe. He looked under the bed. He looked in the chair. Chad looked on top of the toy car. He still could not find his shoe.

Color the circle and then find the answer in the passage. Highlight the answer or the clue using the same color crayon.

1.  What did Chad lose?

\_\_\_\_\_

-----

\_\_\_\_\_

2.  Where did he look first?

\_\_\_\_\_

-----

\_\_\_\_\_

3.  Where did he look next?

\_\_\_\_\_

-----

\_\_\_\_\_

4.  Was the shoe on the toy car?

\_\_\_\_\_

-----

\_\_\_\_\_

5.  Where is Chad's shoe?

\_\_\_\_\_

-----

\_\_\_\_\_

Name \_\_\_\_\_

# Making Arrays and Repeated Addition

Directions: Draw snowflake arrays for each set. Write an addition problem.  
The first one has been done for you. Use the last slate to write your own set.

2 rows of 2

$2+2=4$

2 rows of 4

3 rows of 3

2 rows of 5

3 rows of 4

2 rows of 3

3 rows of 2

3 rows of 5



Name \_\_\_\_\_

# Long e Vowel Teams

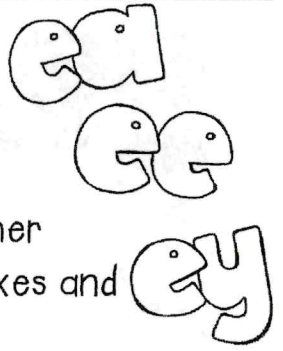

Directions: Look at the pictures in the box. Each word has either an -ea, ee or -ey vowel team. Spell out the words in the sound boxes and complete each sentence with the correct word.

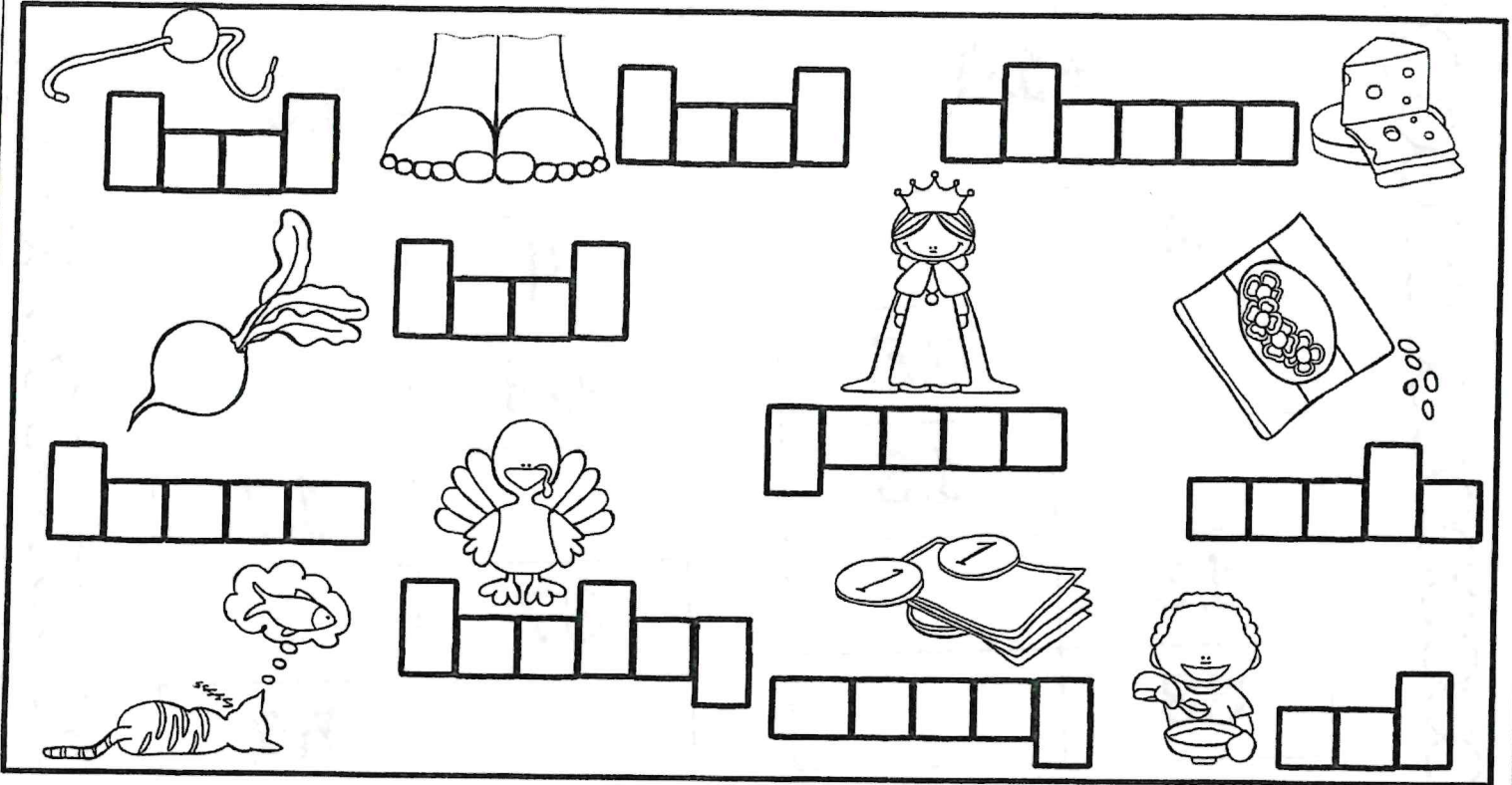

1. We planted some \_\_\_\_\_ in our garden.
2. I have a lot of \_\_\_\_\_ in my piggy bank.
3. We like to eat \_\_\_\_\_ on Thanksgiving.
4. I pulled a \_\_\_\_\_ from my garden
5. The king and \_\_\_\_\_ sat on their throne.
6. I had a funny \_\_\_\_\_ when I was sleeping last night.
7. I love to \_\_\_\_\_ soup when it is cold outside.
8. Grilled \_\_\_\_\_ is my favorite sandwich.
9. My \_\_\_\_\_ are too big for my shoes.
10. Can you string that \_\_\_\_\_ for a necklace?



Name: \_\_\_\_\_

What goes in the box?

Adding 10!



3	
	25
	18
16	
33	



9	
49	
	17
37	
	52



16	
	48
24	
	34
45	

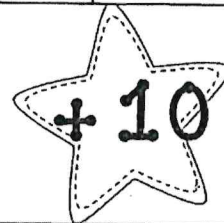

	35
14	
73	
	12
57	

Name: \_\_\_\_\_

# Abraham Lincoln Timeline

Directions: Cut and paste each event under the correct time.

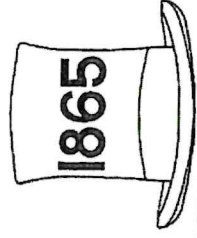
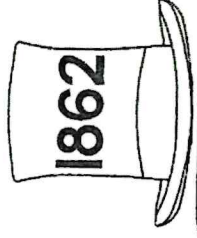
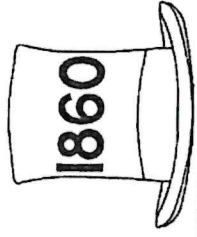
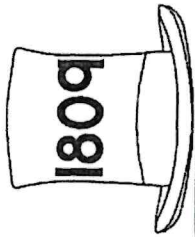

He was elected president.

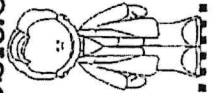

He was shot and killed.

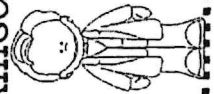

Slavery was abolished.

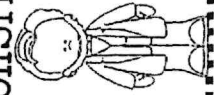

He married Mary Todd.

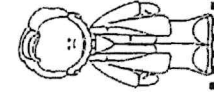

Abraham Lincoln was born.

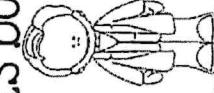



# Day 6

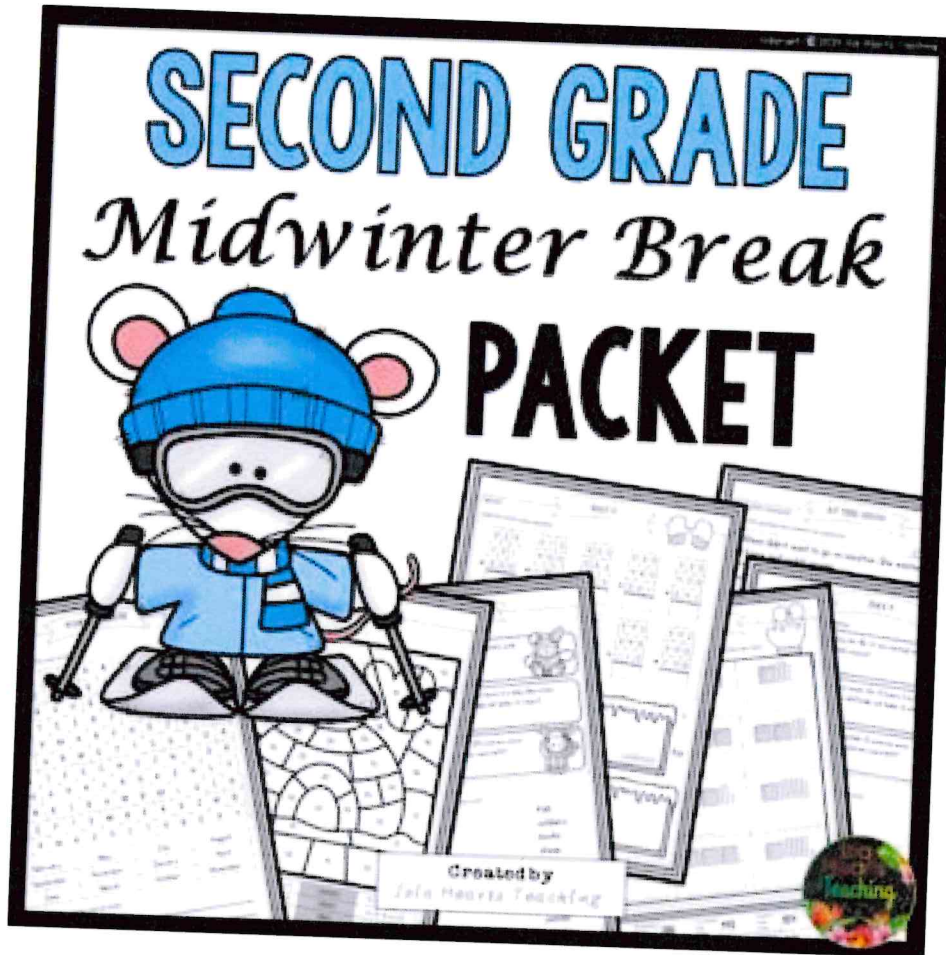

# 2<sup>nd</sup> Grade







It snowed all day. It snowed all night. There was no school. The snow was too deep. The house was covered in snow. Then the sun came out and it melted.

Color the circle and then find the answer in the passage. Highlight the answer or the clue using the same color crayon.

1.  When did it snow?

2.  Why was there no school?

3.  What would you do if there was a snow day?

4.  How deep do you think the snow was?

5.  What happened when the snow melted?

Name \_\_\_\_\_

# Long a Vowel Teams

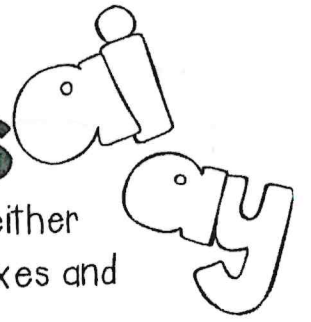

Directions: Look at the pictures in the box. Each word has either an -ai or -ay vowel team. Spell out the words in the sound boxes and complete each sentence with the correct word.

1. You need to \_\_\_\_\_ for that toy.
2. I taught my dog how to sit and \_\_\_\_\_.
3. I can't hear you. What did you \_\_\_\_\_?
4. On my \_\_\_\_\_, I like to have cake and ice cream.
5. The postman came with the \_\_\_\_\_.
6. Make the \_\_\_\_\_ strong so it won't break.
7. My horse is eating \_\_\_\_\_.
8. My \_\_\_\_\_ helps me think.
9. I will bring my umbrella in case it starts to \_\_\_\_\_.
10. My dog wags her \_\_\_\_\_ when she is happy.



Name: \_\_\_\_\_

# Domino Fact Families!

Directions: Look at the domino. Write the 4 number sentences that go with it.

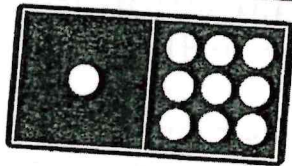

$$\begin{array}{l} \underline{\quad} + \underline{\quad} = \underline{\quad} \\ \underline{\quad} + \underline{\quad} = \underline{\quad} \\ \underline{\quad} - \underline{\quad} = \underline{\quad} \\ \underline{\quad} - \underline{\quad} = \underline{\quad} \end{array}$$

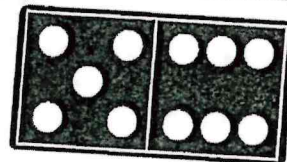

$$\begin{array}{l} \underline{\quad} + \underline{\quad} = \underline{\quad} \\ \underline{\quad} + \underline{\quad} = \underline{\quad} \\ \underline{\quad} - \underline{\quad} = \underline{\quad} \\ \underline{\quad} - \underline{\quad} = \underline{\quad} \end{array}$$

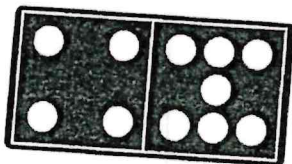

$$\begin{array}{l} \underline{\quad} + \underline{\quad} = \underline{\quad} \\ \underline{\quad} + \underline{\quad} = \underline{\quad} \\ \underline{\quad} - \underline{\quad} = \underline{\quad} \\ \underline{\quad} - \underline{\quad} = \underline{\quad} \end{array}$$

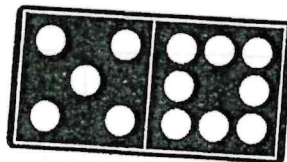

$$\begin{array}{l} \underline{\quad} + \underline{\quad} = \underline{\quad} \\ \underline{\quad} + \underline{\quad} = \underline{\quad} \\ \underline{\quad} - \underline{\quad} = \underline{\quad} \\ \underline{\quad} - \underline{\quad} = \underline{\quad} \end{array}$$

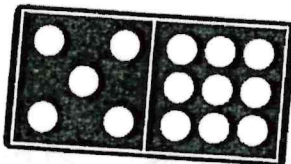

$$\begin{array}{l} \underline{\quad} + \underline{\quad} = \underline{\quad} \\ \underline{\quad} + \underline{\quad} = \underline{\quad} \\ \underline{\quad} - \underline{\quad} = \underline{\quad} \\ \underline{\quad} - \underline{\quad} = \underline{\quad} \end{array}$$

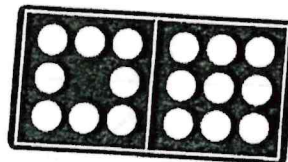

$$\begin{array}{l} \underline{\quad} + \underline{\quad} = \underline{\quad} \\ \underline{\quad} + \underline{\quad} = \underline{\quad} \\ \underline{\quad} - \underline{\quad} = \underline{\quad} \\ \underline{\quad} - \underline{\quad} = \underline{\quad} \end{array}$$



# Which Liquids Will Freeze in the Winter Weather?

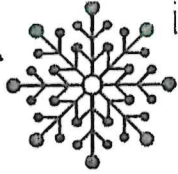

Name: \_\_\_\_\_

- 1) Record all liquids being tested.
- 2) Make predictions on if each item will freeze or if it will remain a liquid when left outside overnight in the winter weather.
- 3) Record the results.

1) This liquid is ...	2) When left outside overnight, I predict that this liquid will...	3) My results:



In this experiment, I learned... \_\_\_\_\_

