

Kindergarten families-

Please help your child complete one packet per snow day. Make sure each page has their name on it. Have your child return it to his/her classroom teacher on the next school day.

We will be available from 9:00 a.m.-1:00 p.m. if you have any questions. Please don't hesitate to contact us through email or Dojo.

Thank you for all that you do to help your child be successful.

Seymour Kindergarten Teachers

Mrs. Burress - [aburress@seymourschool.net](mailto:aburress@seymourschool.net)

Ms. Fry - [hfry@seymourschool.net](mailto:hfry@seymourschool.net)

Mrs. Smith - [ssmith@seymourschool.net](mailto:ssmith@seymourschool.net)



# Kindergarten

## Day 1





Name: \_\_\_\_\_

# All You Need for a Snowman

1. Scan the story next to the book.  
Listen to the story.
2. Scan the code to hear the instructions.

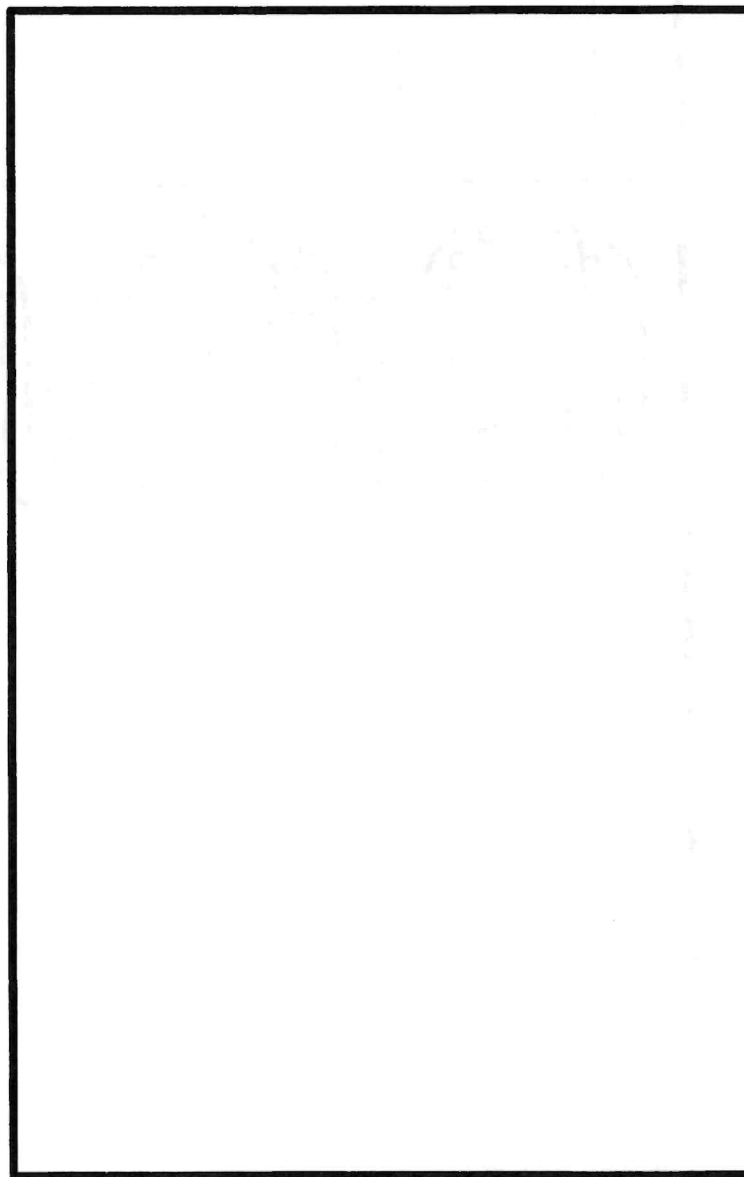
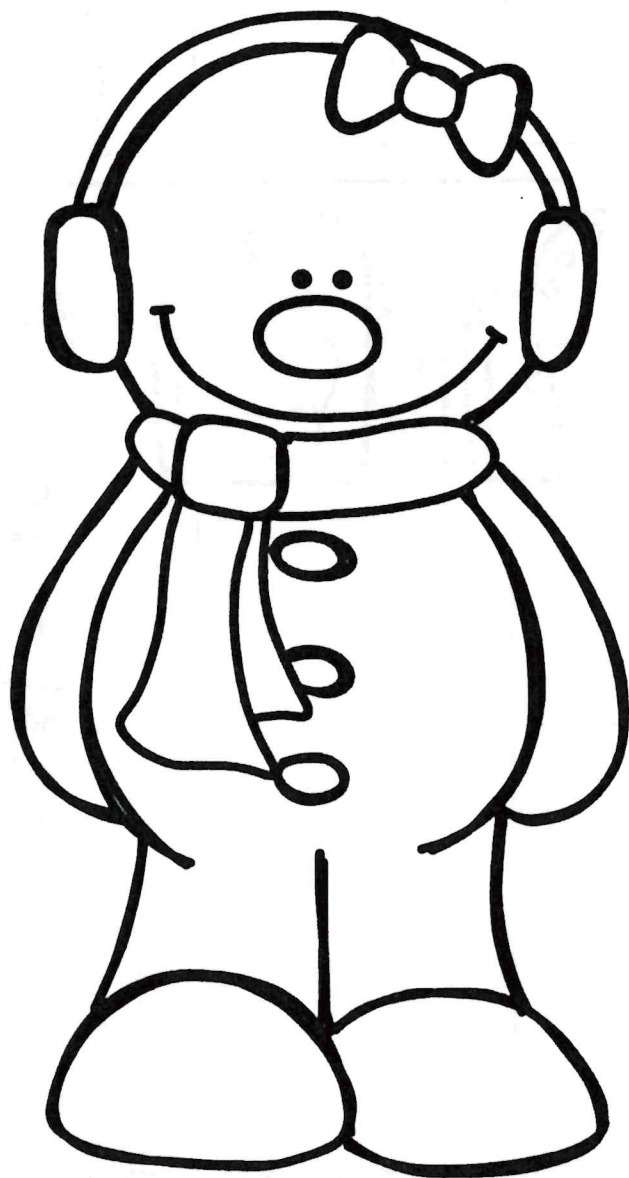
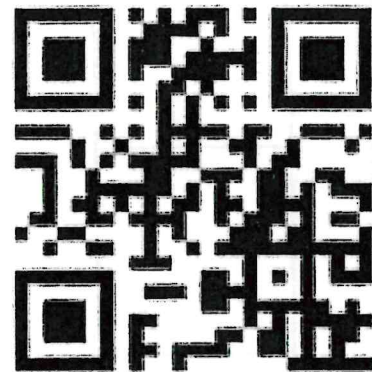
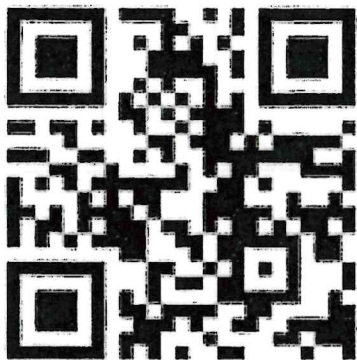
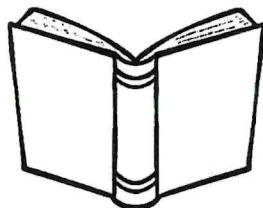

Name: \_\_\_\_\_  
Look at the picture. Write the CVC word that matches!

# SKATING WITH CVC WORDS

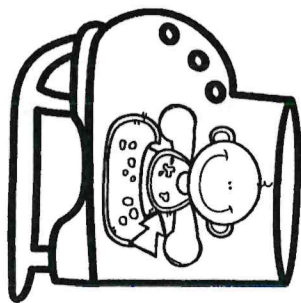
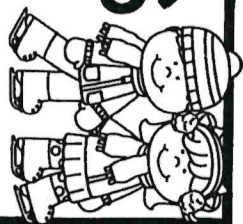

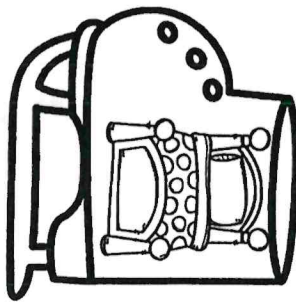

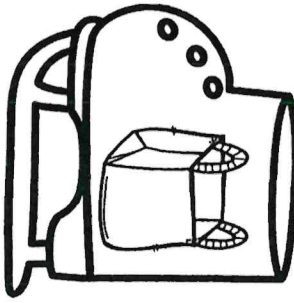

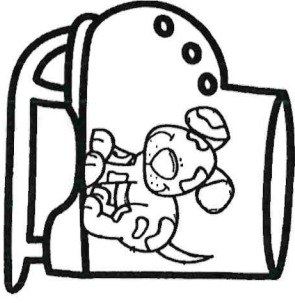

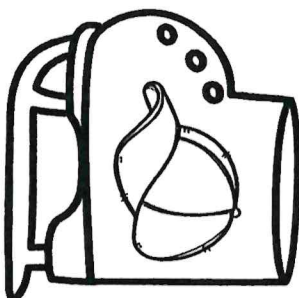

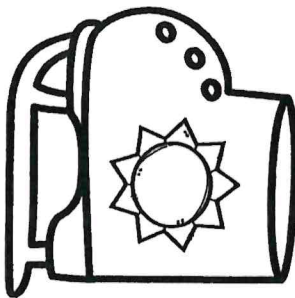

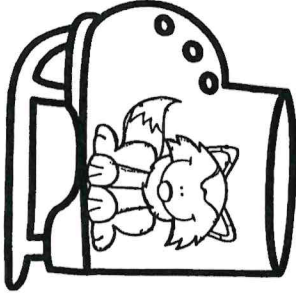

Name: \_\_\_\_\_

# MY CAT

My black cat is fat. He likes to nap.

My cat can see a rat. The rat ran by  
the cat. My fat cat will not get up.

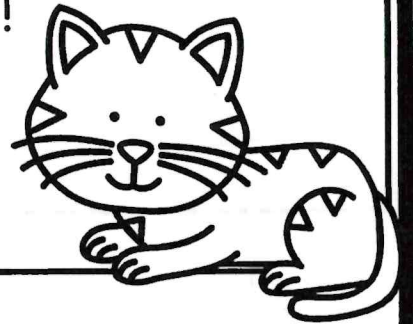
He will nap and nap. Bad cat!



What color was the cat?

blue

brown

black

What did the cat like to do?

run

nap

fat

Who ran by the cat?

---

---

---



# Fab 5 for Writing



Stretch out your words.

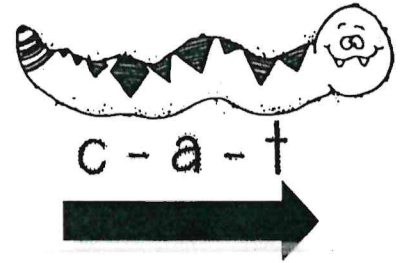

Use capital letters at the beginning of your sentences and for proper nouns.

My name is Sam.

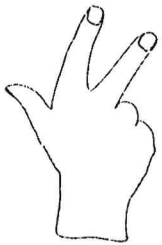

Use finger space.

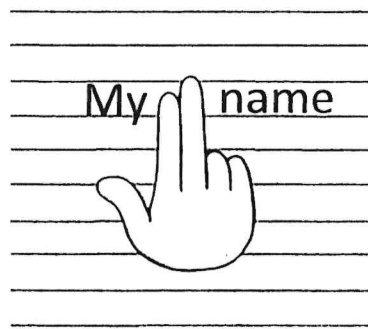

Use punctuation marks at the end of your sentences.

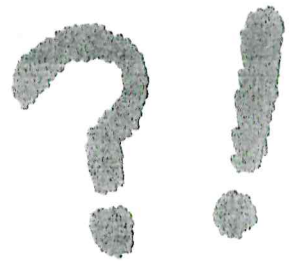

Check your work.  
Does your writing make sense?



Name: \_\_\_\_\_

1. Color the picture

2. Use it to write about what you see.

3. Complete both sentences.



The dog

Name: \_\_\_\_\_

Date: \_\_\_\_\_

## Addition Worksheets

$$\begin{array}{r} 3 \\ +1 \\ \hline \end{array}$$

$$\begin{array}{r} 3 \\ +3 \\ \hline \end{array}$$

$$\begin{array}{r} 1 \\ +2 \\ \hline \end{array}$$

$$\begin{array}{r} 6 \\ +6 \\ \hline \end{array}$$

$$\begin{array}{r} 4 \\ +6 \\ \hline \end{array}$$

$$\begin{array}{r} 2 \\ +5 \\ \hline \end{array}$$

$$\begin{array}{r} 1 \\ +5 \\ \hline \end{array}$$

$$\begin{array}{r} 2 \\ +3 \\ \hline \end{array}$$

$$\begin{array}{r} 1 \\ +2 \\ \hline \end{array}$$

$$\begin{array}{r} 3 \\ +6 \\ \hline \end{array}$$

$$\begin{array}{r} 0 \\ +3 \\ \hline \end{array}$$

$$\begin{array}{r} 5 \\ +4 \\ \hline \end{array}$$

$$\begin{array}{r} 2 \\ +3 \\ \hline \end{array}$$

$$\begin{array}{r} 5 \\ +5 \\ \hline \end{array}$$

$$\begin{array}{r} 6 \\ +5 \\ \hline \end{array}$$

$$\begin{array}{r} 5 \\ +3 \\ \hline \end{array}$$

$$\begin{array}{r} 4 \\ +5 \\ \hline \end{array}$$

$$\begin{array}{r} 5 \\ +5 \\ \hline \end{array}$$

$$\begin{array}{r} 2 \\ +0 \\ \hline \end{array}$$

$$\begin{array}{r} 0 \\ +1 \\ \hline \end{array}$$

$$\begin{array}{r} 1 \\ +4 \\ \hline \end{array}$$

$$\begin{array}{r} 1 \\ +0 \\ \hline \end{array}$$

$$\begin{array}{r} 2 \\ +3 \\ \hline \end{array}$$

$$\begin{array}{r} 5 \\ +5 \\ \hline \end{array}$$

$$\begin{array}{r} 3 \\ +5 \\ \hline \end{array}$$

Name: \_\_\_\_\_

Date: \_\_\_\_\_

## Subtraction worksheets

$1-1=$

$6-1=$

$7-0=$

$5-3=$

$1-0=$

$6-4=$

$7-2=$

$0-0=$

$3-1=$

$8-4=$

$1-0=$

$3-1=$

$9-1=$

$7-2=$

$9-7=$

$1-0=$

$10-9=$

$4-3=$

$1-0=$

$3-0=$

$0-0=$

$8-4=$

$6-1=$

$8-5=$

$1-0=$

$7-1=$

$5-5=$

$5-4=$

$2-1=$

$2-1=$

$5-1=$

$4-3=$

$5-4=$

$6-0=$

$9-9=$





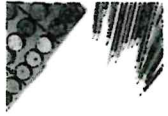

# ART AMI ACTIVITIES 1&2



Mrs. Dean

E-mail: [adean@seymourschool.net](mailto:adean@seymourschool.net) (preferred method of communication)

Phone: 417-207-3844

I will be available for contact from 9 a.m. to 1 p.m.

(If messaged outside time above I will try to respond within an hour)

***Students will complete the art activity only if the snow day falls on the corresponding day that their special class would be art.***

When completing Art activities feel free to use whatever materials you have available.

**Tuesday Special Class**

Garrison  
Piles  
Neal  
Woods  
Burress

**Wednesday Special Class**

Richards  
Neuroth  
L. Johnson  
Plummer  
Smith

**Thursday Special Class**

Lathram  
Nelson  
Thiemann  
Stacey  
Fry

**Friday Special Class**

Terry  
Shelton  
T. Johnson



## Big Face Self Portrait



Here's a drawing that is guaranteed to fill the paper. Students are directed to make their lines touch the edge so you end up with some very large and interesting works of art.

Any kind of media could be used for this, but I find it perfect for a crayon resist as the large sections of the face are so easy and fun to fill with all kinds of patterns. Some of my all time favorite ones have been created by kinders, so it's easy to do.

### NATIONAL ARTS STANDARDS

VA:Cr1.2.2a Make art or design with various materials and tools to explore personal interests, questions, and curiosity.

### DIRECTIONS

- Direct the students or have them follow the tutorial on the following page.
- Students trace the drawing with a black marker.
- Patterns are drawn with crayon on the large areas.
- Fill all the sections with liquid watercolor paint.

### MATERIALS

- Watercolor paper, 9" x 12"
- Black marker
- Crayons
- Liquid watercolor paint

Kindergarten Activity 1



# Big Face SELF PORTRAIT TUTORIAL



Supplies: Marker, crayons, liquid watercolor paint, watercolor paper

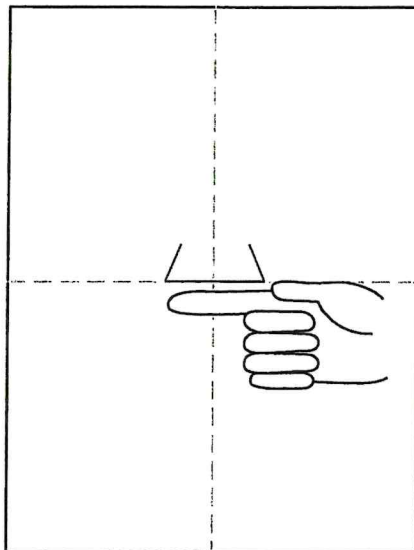

1. Make guide lines. Start the nose.

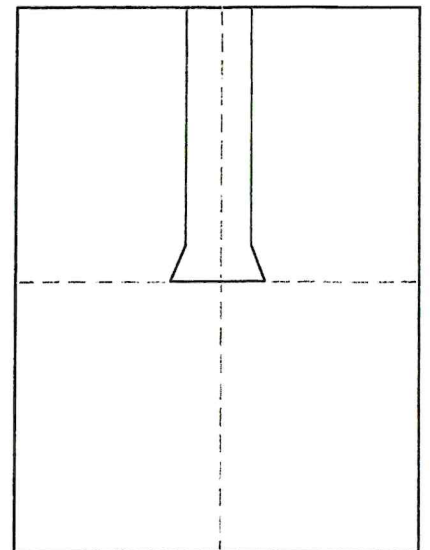

2. Add two lines going up.

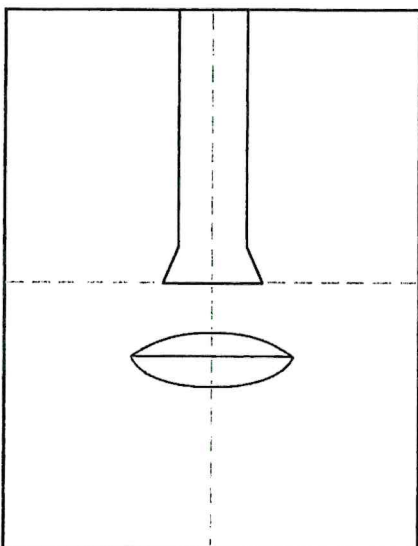

3. Draw a mouth.

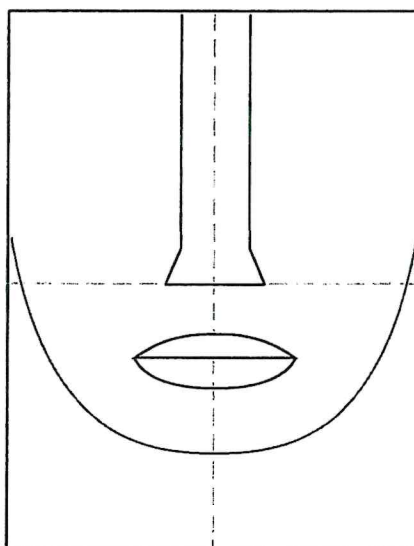

4. Draw the chin.

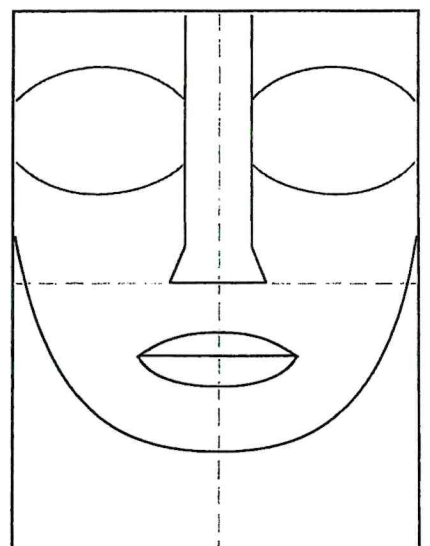

5. Draw four curved lines.

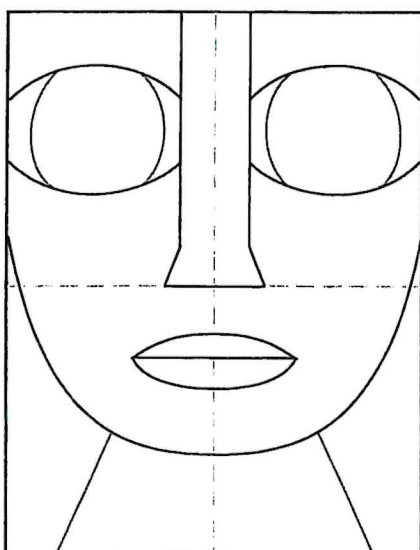

6. Finish the eyes. Add the neck.

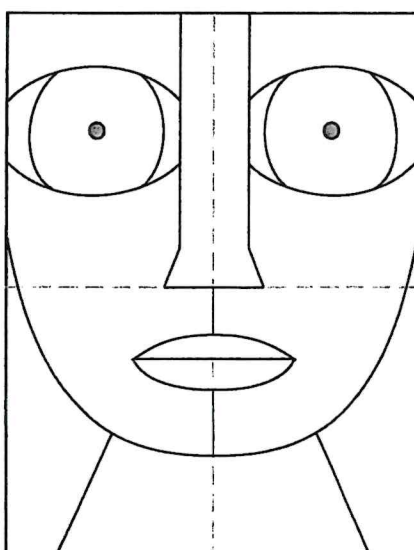

7. Add center of eyes and mouth lines.

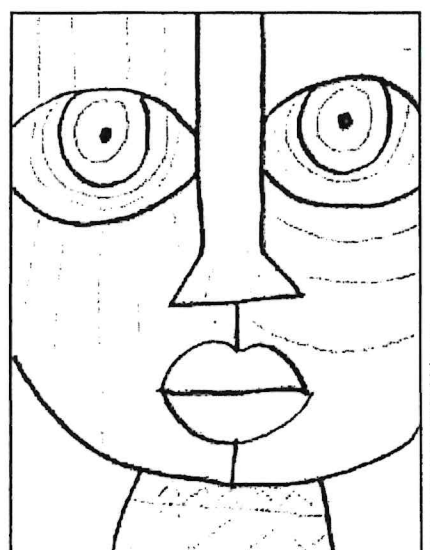

8. Trace, add crayon patterns, paint.



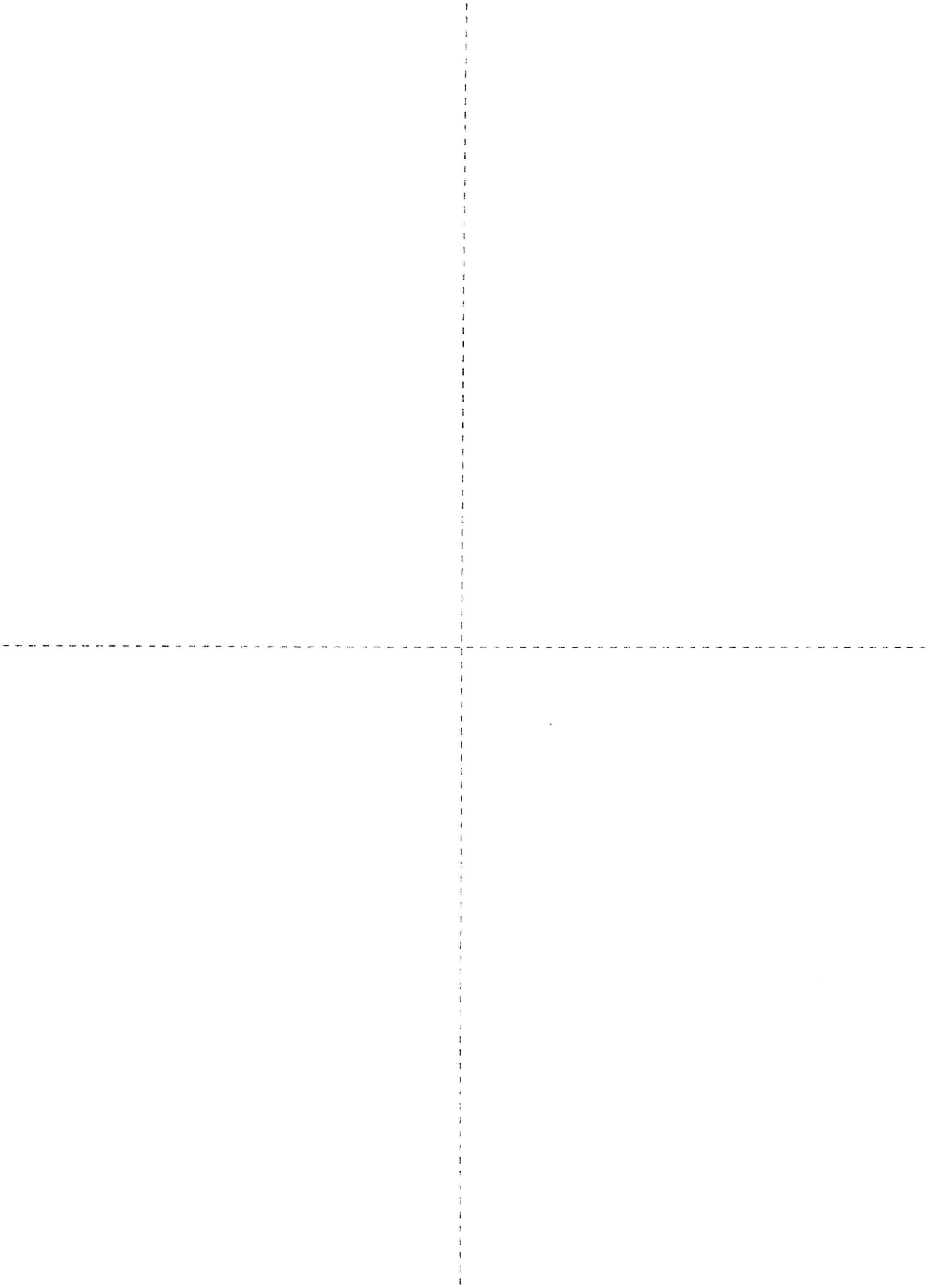







# AMIDAY 1



Physical Education (PE)

Coach Hosiner

Email: [phosiner@seymourschool.net](mailto:phosiner@seymourschool.net) (preferred method of communication)

Phone Number: 417-259-9607

I will be available from 8:00am to 12:00pm to answer questions.

If you message me outside of the times above I will try my best to answer within an hour.

Thank you and enjoy the exercises and activities planned for today!



# AMRAP DIRECTIONS

1. Start at the top exercise
2. Perform the exercise for the designated rep count
3. Go to the next exercise on the round arrow
4. Perform that exercise for the designated rep count
5. Continue around the arrow until all the exercises are complete
6. Repeat the AMRAP exercises if you complete the entire round
7. Perform each AMRAP visual for **5 minutes**

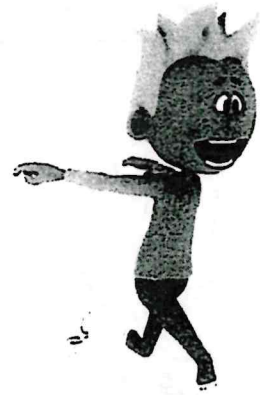

PE AMI-Day 1



# AMRAP

(AS MANY ROUNDS AS POSSIBLE)

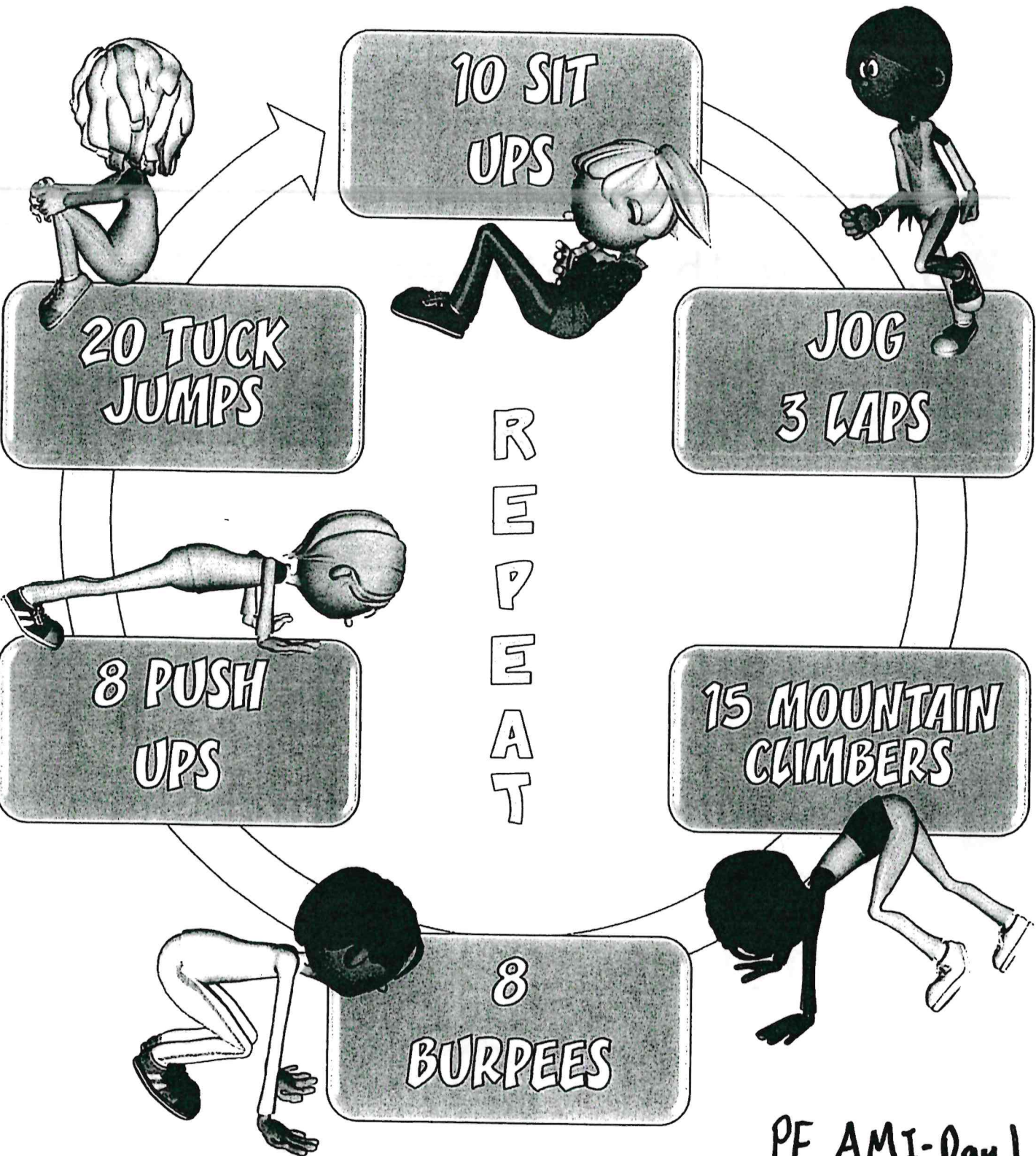



PE AMI-Day 1



# AMI - Computer Lab

[tpatterson@seymourschool.net](mailto:tpatterson@seymourschool.net)

Office Hours: 10:00am - 2:00pm Tuesday-Friday

Please spend 15 minutes each AMI day in one of these programs

Grades 2 - 5	
Typesy	typesy.com/type/ Username and password are the same as your AR username and password.
Tynker	tynker.com  
ABCya	Abcya.com Login: Username: clab Password: tigers

Grade 1	
TypeTastic	Seymour.typetastic.com/login Email me for login information if student cannot remember what it is.
Tynker	tynker.com  
ABCya	Abcya.com Login: Username: clab Password: tigers

Kindergarten	
My Math & My Reading Academy	See attached Getting Started Guide



# My Math Academy®

# My Reading Academy™

## Getting Started Guide

### Welcome, families and caregivers!

We're excited to see your child grow while using *My Math Academy* and *My Reading Academy*! The school-home connection is important, and we hope this Getting Started Guide provides the tools you need to successfully support your child in using Age of Learning's programs at home.

### STEP 1: Set Up Free Home Access

You can set up free home access to Age of Learning's programs using the Redemption Code on the Welcome Letter from your child's classroom teacher:

1. Go to <https://Educate.AofL.com/Parent/Redeem/> and select your preferred language.
2. Enter your Redemption Code in the box.
3. Click **Submit**.
4. Follow the prompts to create your username and password for the Age of Learning products assigned to you.

### STEP 2: Using Age of Learning's Programs

To use *My Math Academy* and *My Reading Academy* at home, follow these steps:

1. Open your preferred browser and go to URL: [Login.AgeofLearning.com](http://Login.AgeofLearning.com)
2. Log in with the email address and password you entered when activating your accounts.
3. Click on your child's profile and their passcode, and then select *My Math Academy* or *My Reading Academy* to begin gameplay.

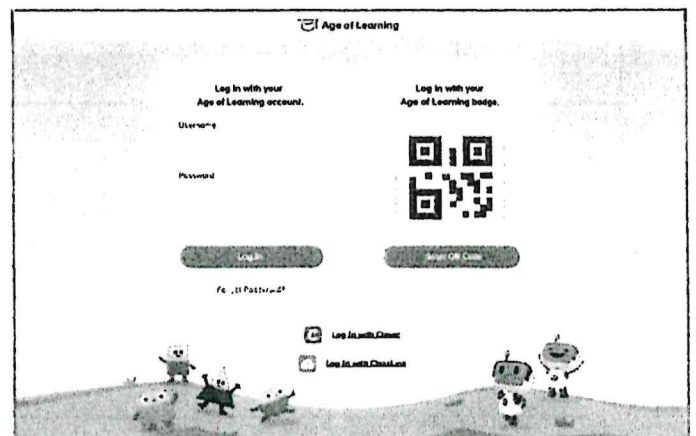

Continued on the back

# TIP

Follow these steps to add the My Math Academy and/or My Reading Academy web link to your iPhone home screen:

1. Open a web browser (such as Safari).
2. Go to our website: [Login.AgeofLearning.com](https://Login.AgeofLearning.com)
3. Tap the **Share** button on the bottom of the page. It looks like a square with an arrow pointing out of the top.
4. In the list of options that appear, scroll down until you see **Add to Home Screen**. Tap this.
5. Choose a name for the website shortcut on your home screen. Click **Add** when you're done.
6. Now tap the new shortcut on your home screen, and it will open the website in its own navigation window.

## STEP 3: Access the Caregiver Center

With the Caregiver Center, you can track your child's usage both at school and at home, review their learning milestones, and find activities to support learning areas where they may need additional support. To access the Caregiver Center, follow these steps:

1. Go to <https://Educate.AofL.com>
2. Log in with your username and password.
3. If you have multiple children, please select the student's name you want to view.

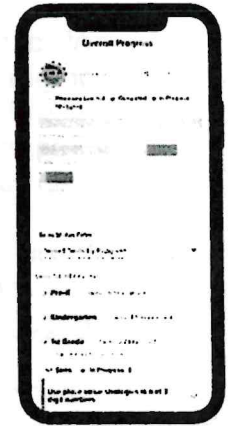
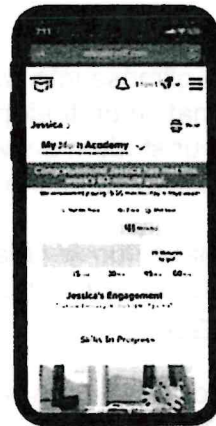

# TIPS

### SUPPORT

Support independent play by encouraging your child to use the programs independently.

### ENCOURAGE

Encourage your child to use the programs during available free time, to help them reach their goal of 45–60 minutes of use per week!

### MOTIVATE

Motivate your child with small rewards for reaching their weekly usage goal!



Access the Help Center  
to Learn More!

[www.AgeofLearning.com/Caregivers](https://www.AgeofLearning.com/Caregivers)



Join the Conversation!  
[@AgeofLearning](https://twitter.com/AgeofLearning)

Dear Caregivers,

We are excited to share a winter break incentive program for *My Math Academy*<sup>®</sup> and *My Reading Academy*<sup>™</sup> designed to extend your child's learning over the holidays.

*My Math Academy* and *My Reading Academy* are adaptive, research-backed programs for pre-K through 2nd grade students. These personalized programs support the individual learning needs of each student, helping them build confidence and develop essential math and reading skills.

Access to these programs is not limited to school. Enclosed are some materials to assist you in setting up your child's account on a home device. Students can access the programs at home in two ways:

**1. QR Code**

- Use this login method if a QR code is attached to this letter.

**2. Redemption Code**

- Follow the Caregiver Getting Started Guide for more information.

We'd love for you to encourage your student to log in over winter break and work in each program. This will give you a glimpse into what your child experiences in the classroom, as well as offering you information on their progress. Due to the adaptability of these programs, please be sure your student answers each question on their own, as extra help can affect the academic level of their experience.

If you would like more information on *My Math Academy* and *My Reading Academy* or have additional questions, please visit our Caregiver Help Center at [AgeofLearning.com/Caregivers](https://AgeofLearning.com/Caregivers).

Thank you for your continued support of your child's education!

Sincerely,  
Mrs. Patterson  
Seymour Elementary



**Learn More!**

[AgeofLearning.com/Caregivers](https://AgeofLearning.com/Caregivers)



# Music AMI Day 1

Teacher: Mrs. Rechtfertig



Email: [arechtfertig@seymourschool.net](mailto:arechtfertig@seymourschool.net)

Office hours: 9am-1pm

Name: \_\_\_\_\_

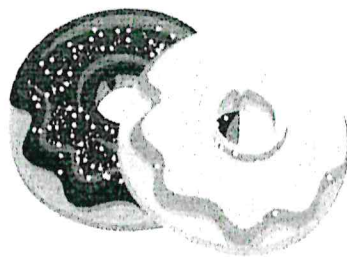

Sometimes notes are placed on a LINE like this:

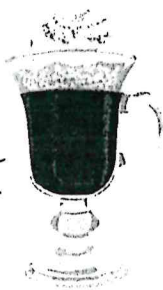
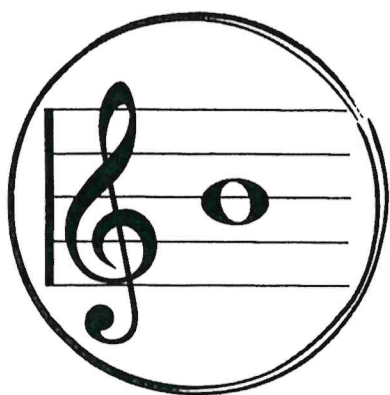

Sometimes notes are placed in a SPACE like this:



To determine where each note is on the staff, you count from the **BOTTOM** to the **TOP**.

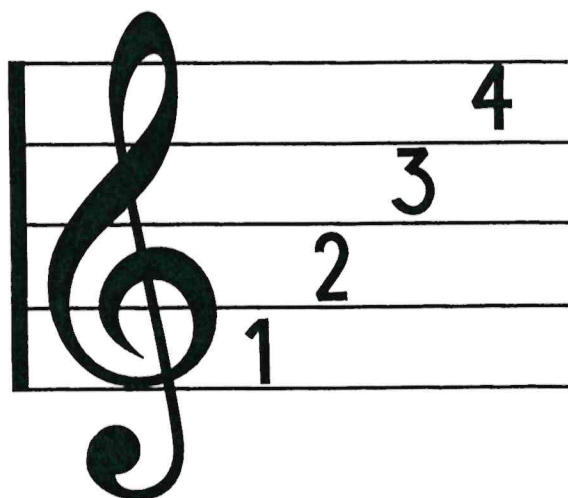
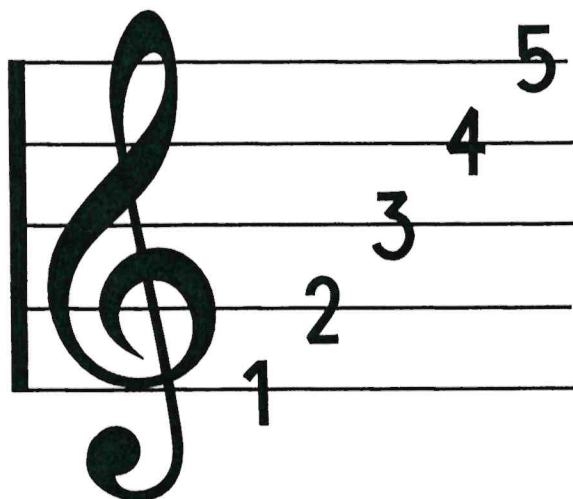

Name: \_\_\_\_\_

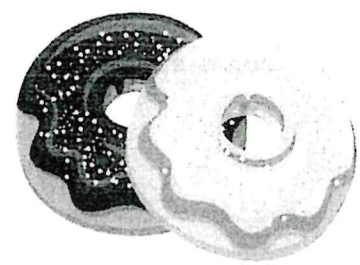

Each note is placed in a space or on a line. Determine if the note is a space or a line and circle your answer below.

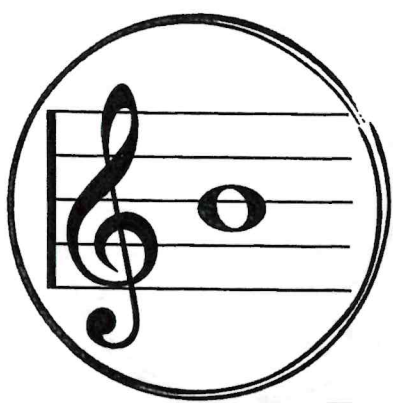

Space **Line**

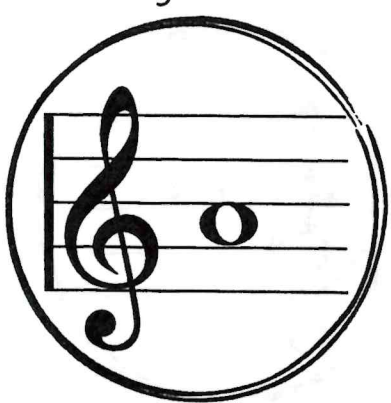

Space Line



Space Line

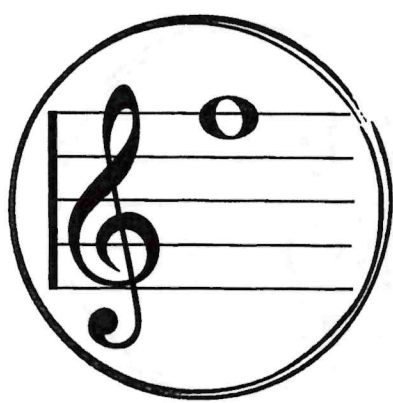

Space Line

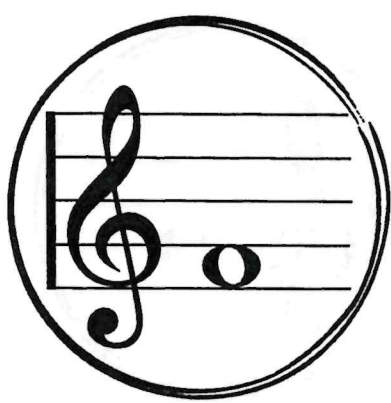

Space Line

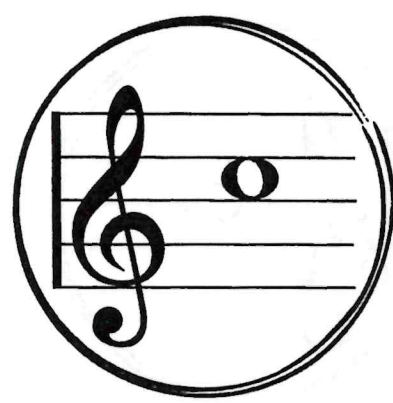

Space Line

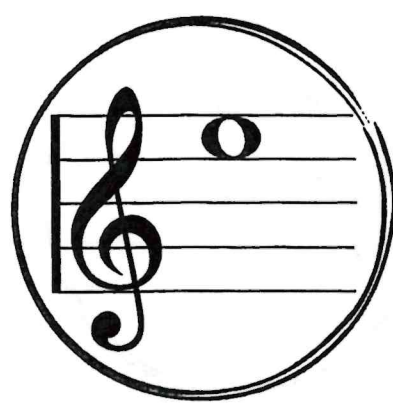

Space Line



Space Line



Space Line

Name: \_\_\_\_\_

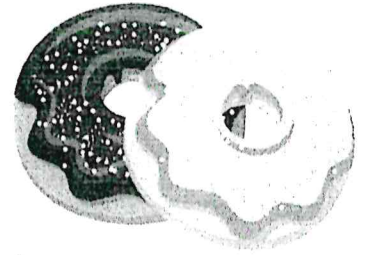

Each note is placed in a space or on a line. Determine if the note is a space or a line and circle your answer below.

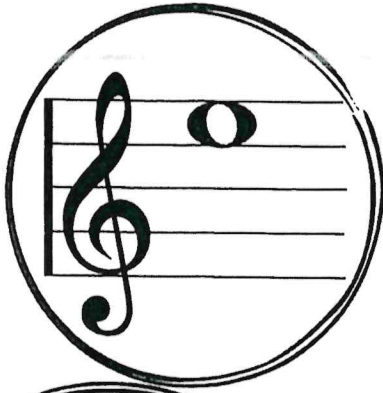

**Space** Line



**Space** Line

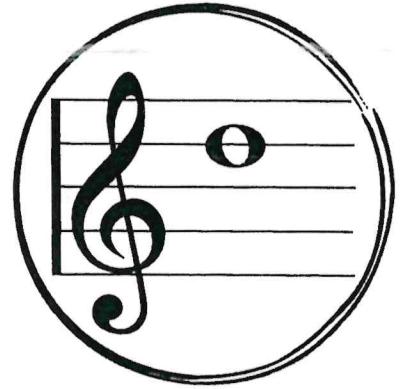

**Space** Line



**Space** Line



**Space** Line



**Space** Line



**Space** Line



**Space** Line



**Space** Line

# Kindergarten

## Day 2





Name: \_\_\_\_\_

# The Mitten

1. Scan the story next to the book.  
Listen to the story.

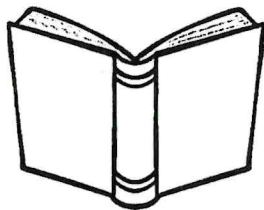

2. Scan the code to hear the instructions.

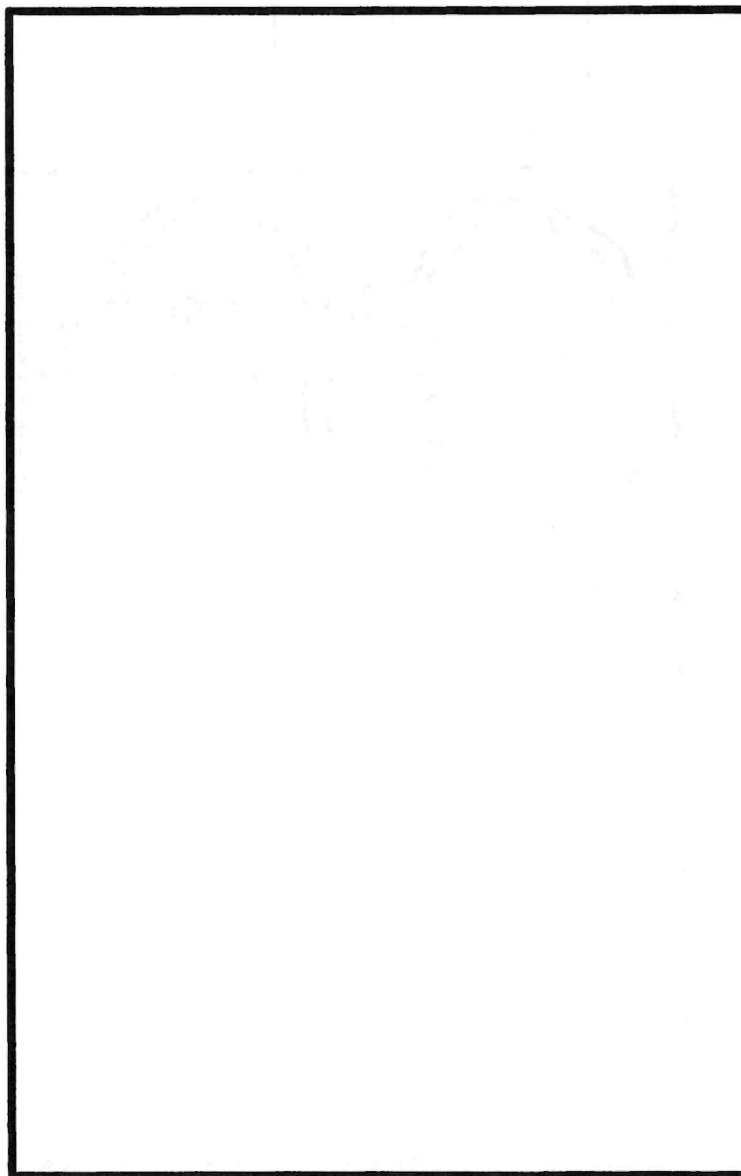
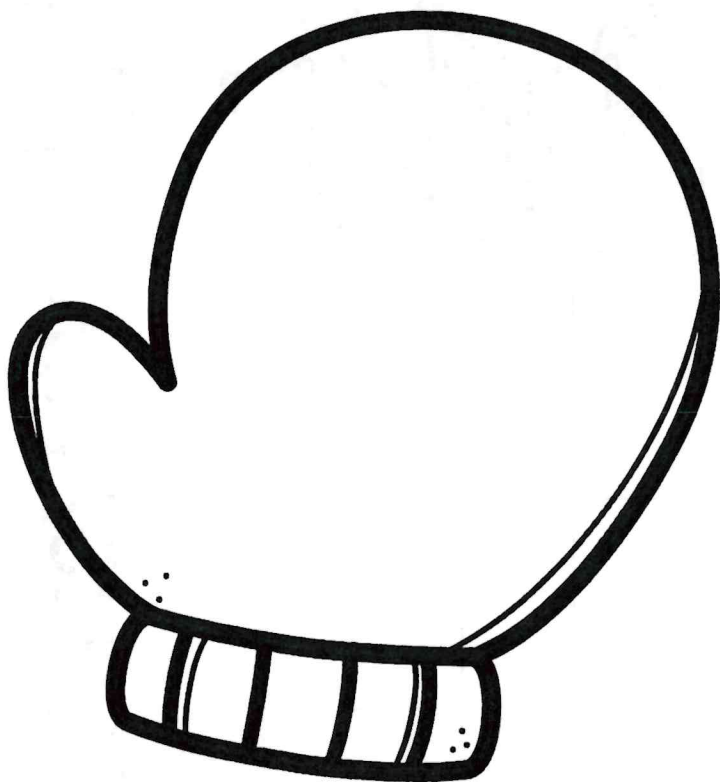

Name: \_\_\_\_\_  
Look at the picture. Write the CVC word that matches!

# SKATING WITH CVC WORDS

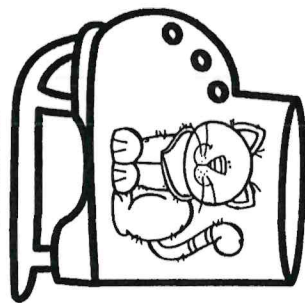
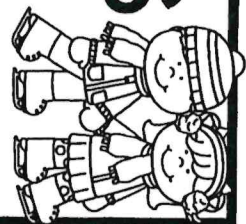

--	--	--

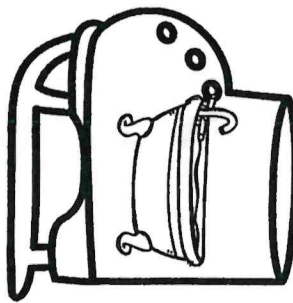

--	--	--

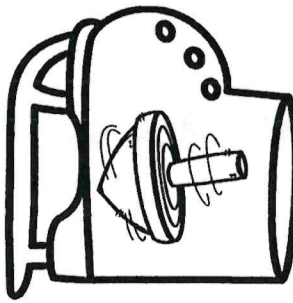

--	--	--

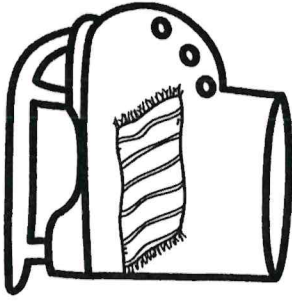

--	--	--

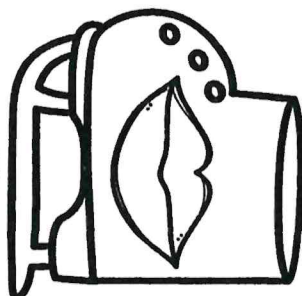

--	--	--

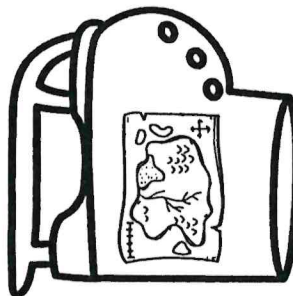

--	--	--

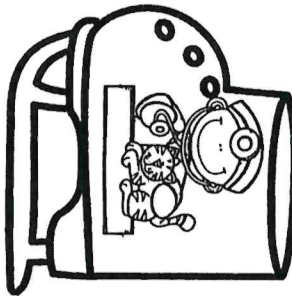

--	--	--

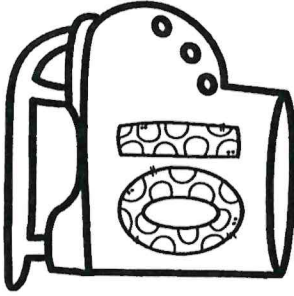

--	--	--



Name: \_\_\_\_\_

# MY PET WAGS

This is my pet. My pet can wag. My pet can see a cat. He will wag. My pet can see the ham. He will wag and wag. My pet likes ham.

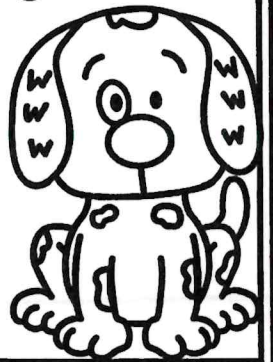

What can my pet do?

wag

tag

run

What can my pet see?

jam

ham

yams

What does my pet like?

---

---

---

# Fab 5 for Writing



Stretch out your words.

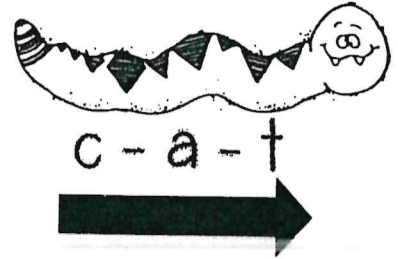

Use capital letters at the beginning of your sentences and for proper nouns.

My name is Sam.



Use finger space.

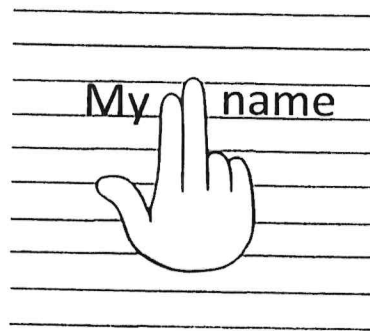

Use punctuation marks at the end of your sentences.

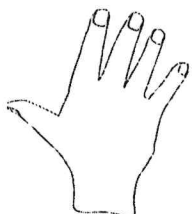
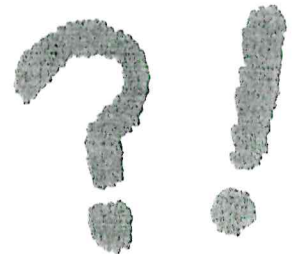

Check your work.  
Does your writing make sense?



Name: \_\_\_\_\_

# Writing

1. Color the picture

3. Write 2 sentences.

2. Use it to write about what you see.

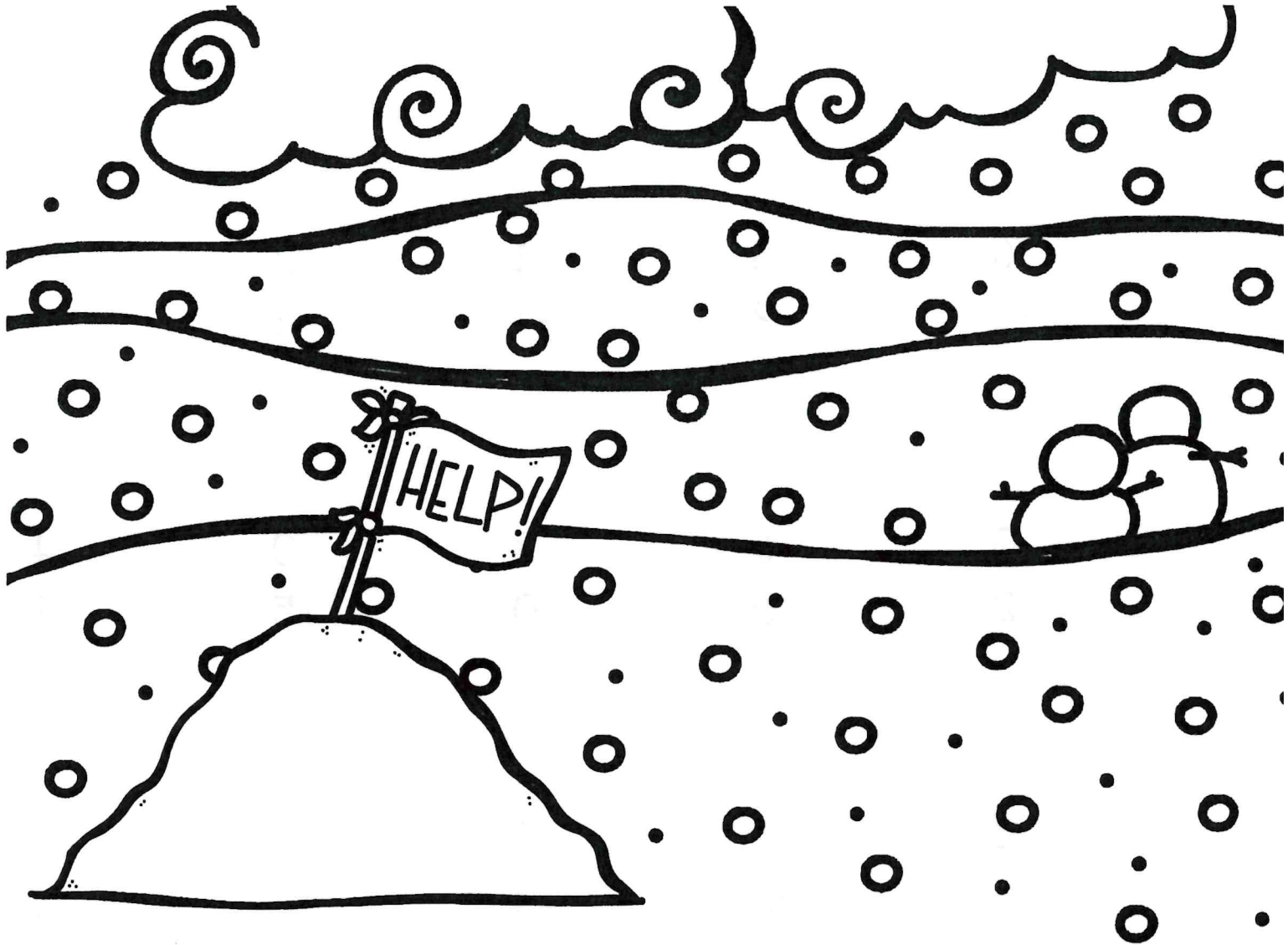

It is

Name: \_\_\_\_\_

Date: \_\_\_\_\_

Date: \_\_\_\_\_

## Addition Worksheets

$$\begin{array}{r} 3 \\ +3 \\ \hline \end{array}$$

$$\begin{array}{r} 5 \\ +2 \\ \hline \end{array}$$

$$\begin{array}{r} 0 \\ +1 \\ \hline \end{array}$$

$$\begin{array}{r} 4 \\ +1 \\ \hline \end{array}$$

$$\begin{array}{r} 2 \\ +5 \\ \hline \end{array}$$

$$\begin{array}{r} 6 \\ +1 \\ \hline \end{array}$$

$$\begin{array}{r} 3 \\ +2 \\ \hline \end{array}$$

$$\begin{array}{r} 1 \\ +4 \\ \hline \end{array}$$

$$\begin{array}{r} 2 \\ +2 \\ \hline \end{array}$$

$$\begin{array}{r} 1 \\ +1 \\ \hline \end{array}$$

$$\begin{array}{r} 0 \\ +2 \\ \hline \end{array}$$

$$\begin{array}{r} 6 \\ +5 \\ \hline \end{array}$$

$$\begin{array}{r} 3 \\ +0 \\ \hline \end{array}$$

$$\begin{array}{r} 0 \\ +5 \\ \hline \end{array}$$

$$\begin{array}{r} 4 \\ +6 \\ \hline \end{array}$$

$$\begin{array}{r} 2 \\ +6 \\ \hline \end{array}$$

$$\begin{array}{r} 4 \\ +3 \\ \hline \end{array}$$

$$\begin{array}{r} 1 \\ +4 \\ \hline \end{array}$$

$$\begin{array}{r} 3 \\ +2 \\ \hline \end{array}$$

$$\begin{array}{r} 5 \\ +1 \\ \hline \end{array}$$

$$\begin{array}{r} 5 \\ +5 \\ \hline \end{array}$$

$$\begin{array}{r} 1 \\ +2 \\ \hline \end{array}$$

$$\begin{array}{r} 4 \\ +4 \\ \hline \end{array}$$

$$\begin{array}{r} 3 \\ +5 \\ \hline \end{array}$$

$$\begin{array}{r} 1 \\ +6 \\ \hline \end{array}$$

Name: \_\_\_\_\_

Date: \_\_\_\_\_

## Subtraction worksheets

$4-0=$        $0-0=$        $8-7=$        $9-0=$        $8-1=$

$10-6=$        $1-1=$        $9-8=$        $7-6=$        $8-1=$

$6-5=$        $2-1=$        $8-1=$        $4-3=$        $2-2=$

$4-3=$        $2-1=$        $7-3=$        $2-1=$        $7-1=$

$2-1=$        $6-5=$        $3-3=$        $6-2=$        $6-2=$

$8-7=$        $7-4=$        $2-0=$        $2-1=$        $3-1=$

$5-4=$        $6-1=$        $9-1=$        $1-1=$        $9-3=$







---

# ART AMI ACTIVITIES 1&2

---

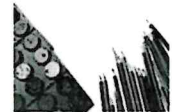

Mrs. Dean

E-mail: [adean@seymourschool.net](mailto:adean@seymourschool.net) (preferred method of communication)

Phone: 417-207-3844

I will be available for contact from 9 a.m. to 1 p.m.

(If messaged outside time above I will try to respond within an hour)

***Students will complete the art activity only if the snow day falls on the corresponding day that their special class would be art.***

When completing Art activities feel free to use whatever materials you have available.

**Tuesday Special Class**

Garrison  
Piles  
Neal  
Woods  
Burress

**Wednesday Special Class**

Richards  
Neuroth  
L. Johnson  
Plummer  
Smith

**Thursday Special Class**

Lathram  
Nelson  
Thiemann  
Stacey  
Fry

**Friday Special Class**

Terry  
Shelton  
T. Johnson





## Draw a Caterpillar

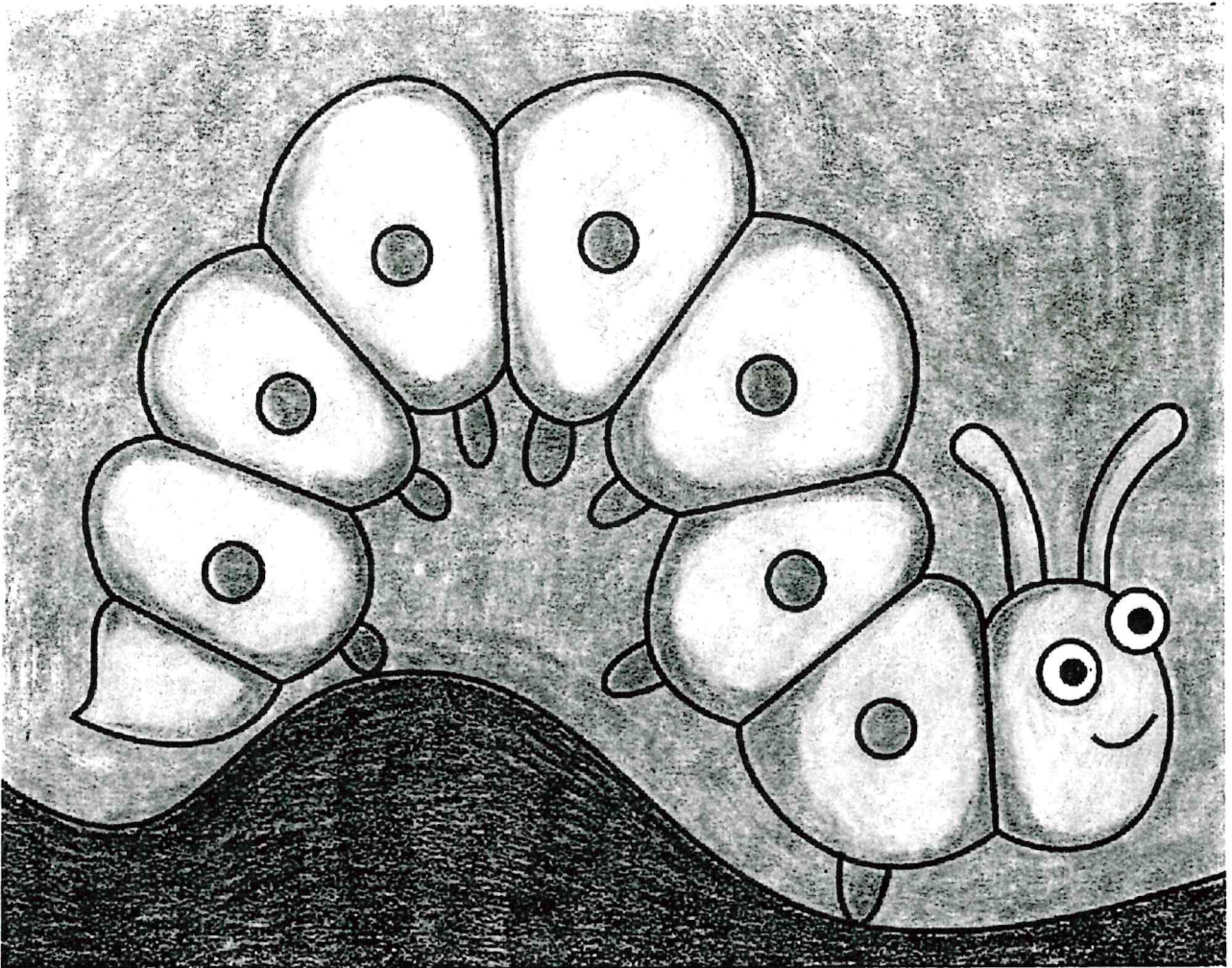

Learn how straight and curved lines can make a caterpillar look like it's made from some very squishy sections. A little shading along the edges adds extra dimension.

### GOAL

Students learn a fun way to draw a caterpillar with sections that look very dimensional.

### ELEMENTS OF ART

Line, Shape, Value, Color

### MATERIALS

- Drawing paper
- Black marker
- Crayons or pencil crayons

### DIRECTIONS

1. Use the tutorial to draw the caterpillar.
2. Trace the drawing with a black marker.
3. Color the caterpillar with crayons or pencil crayons.

Kindergarten Activity 2



# Draw a Caterpillar

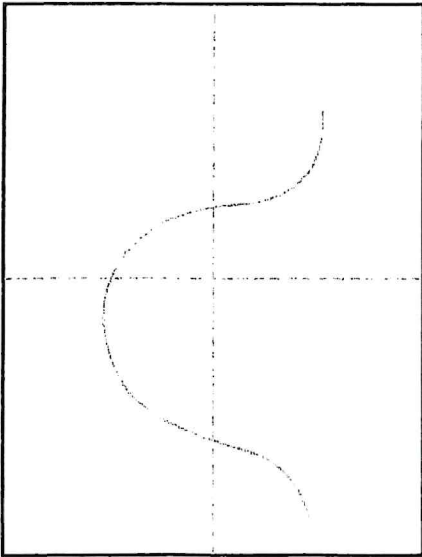

1. Draw the center spine (very lightly).

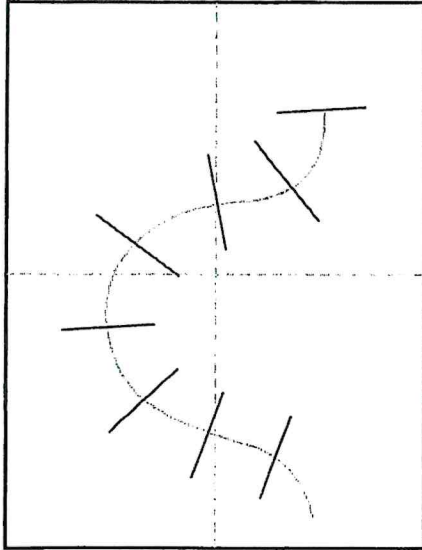

2. Draw eight lines centered on the spine.

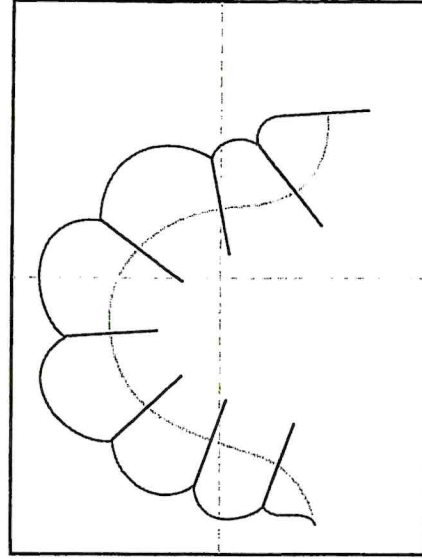

3. Connect the top ends with a curved line.

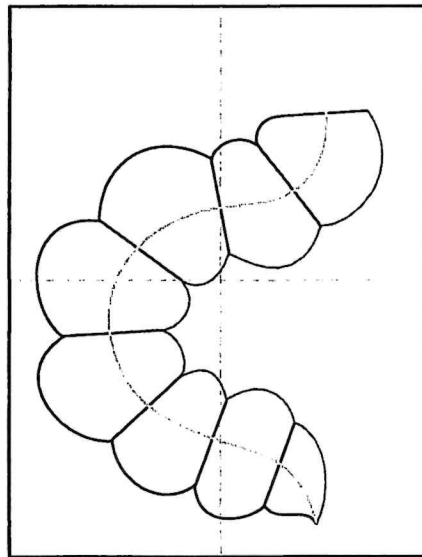

4. Connect the bottom ends with a curved line.

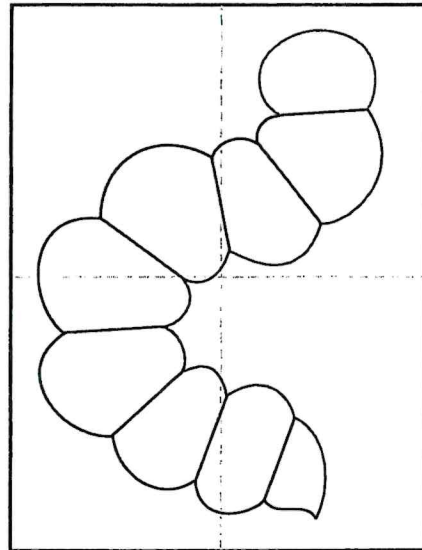

5. Erase the spine line and add the head.

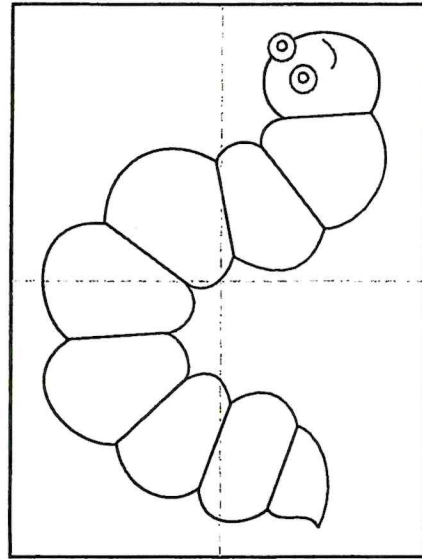

6. Draw eyes and mouth.

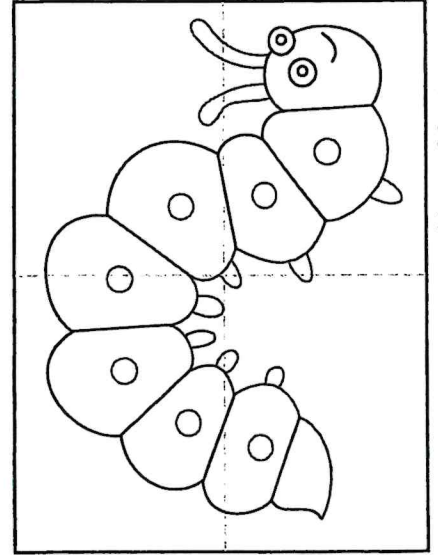

7. Add spots, antennae, and lots of feet.

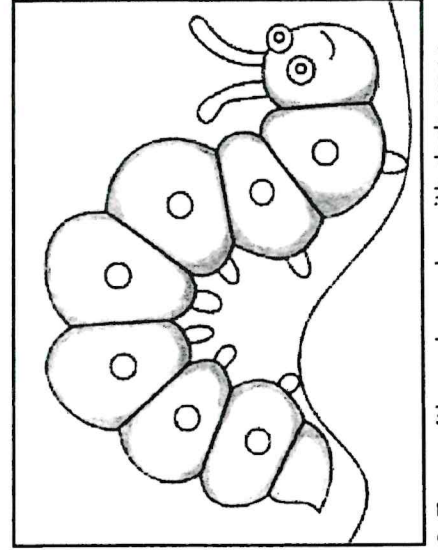

8. Trace with marker, color with dark green.

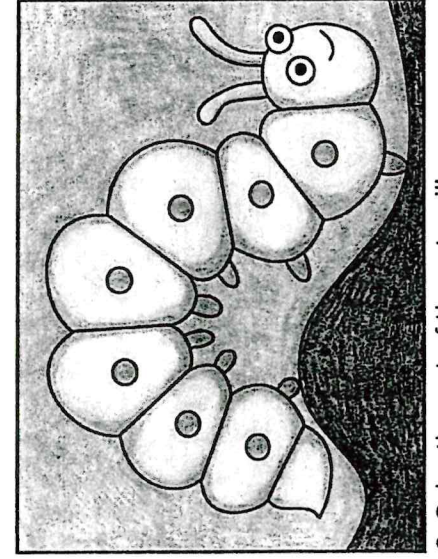

9. Color the rest of the caterpillar.



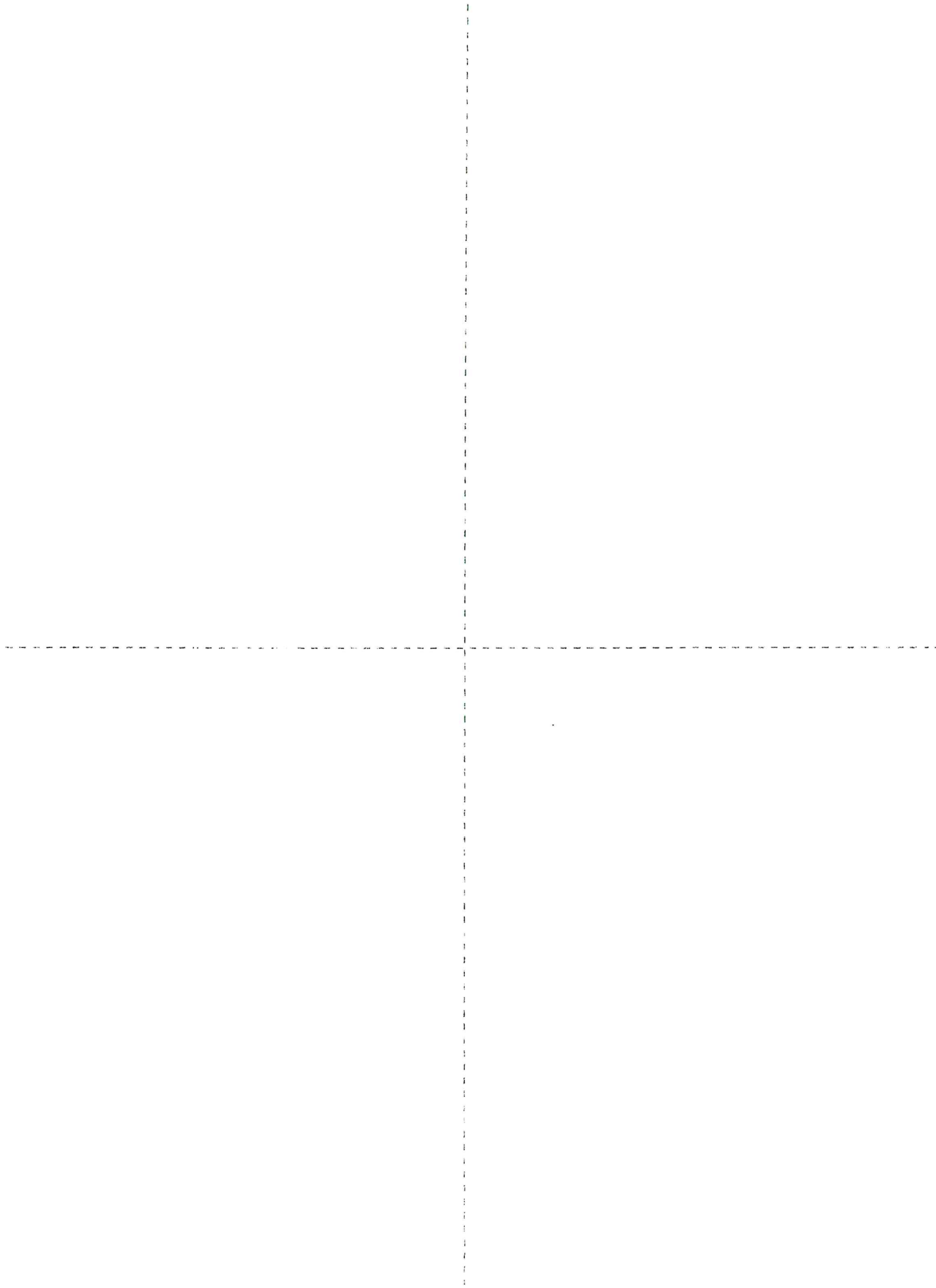







# AMI Day 2

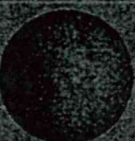

Physical Education (PE)

Coach Hosiner

Email: [phosiner@seymourschool.net](mailto:phosiner@seymourschool.net) (preferred method of communication)

Phone Number: 417-259-9607

I will be available from 8:00am to 12:00pm to answer questions.

If you message me outside of the times above I will try my best to answer within an hour.

Thank you and enjoy the exercises and activities planned for today!





# SKILL FOCUS DIRECTIONS

**Equipment:** *Rolled up socks or beanbags*

**Space:** *Small area inside or outside*

**Safety:** *Don't toss too high...watch your ceilings*



1. Start with the number 1 skill.
2. Perform the skill for the designated time suggested.
3. Go to the next skill challenge.
4. Perform that skill for the designated time suggested.
5. Continue through all 6 skill challenges (12 minutes).
6. If you have time, try the challenges you like best again.



# 2 HAND CATCH

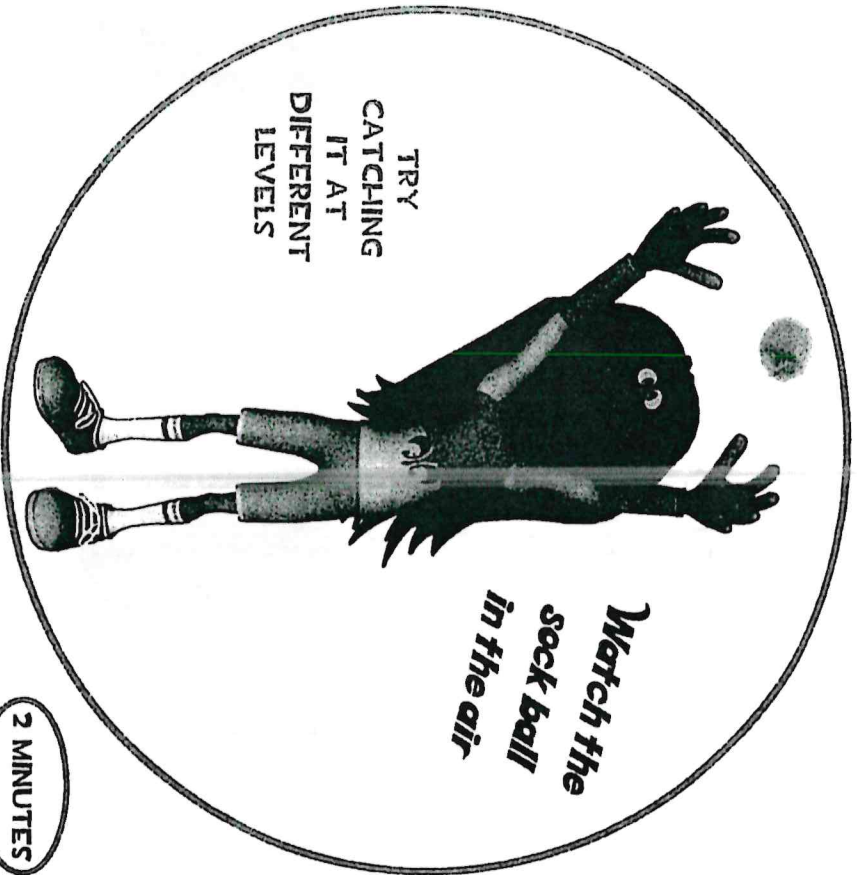

Toss the sock ball up in the air with 1 hand and catch it in front of your body using 2 hands.

1

CATCHING

# 1 HAND CATCH



Toss the sock ball up in the air with 1 or 2 hands and catch it in front of your body using only 1 hand.

2

CATCHING

PE AMI-  
Day 1



# RAINBOW TOSS

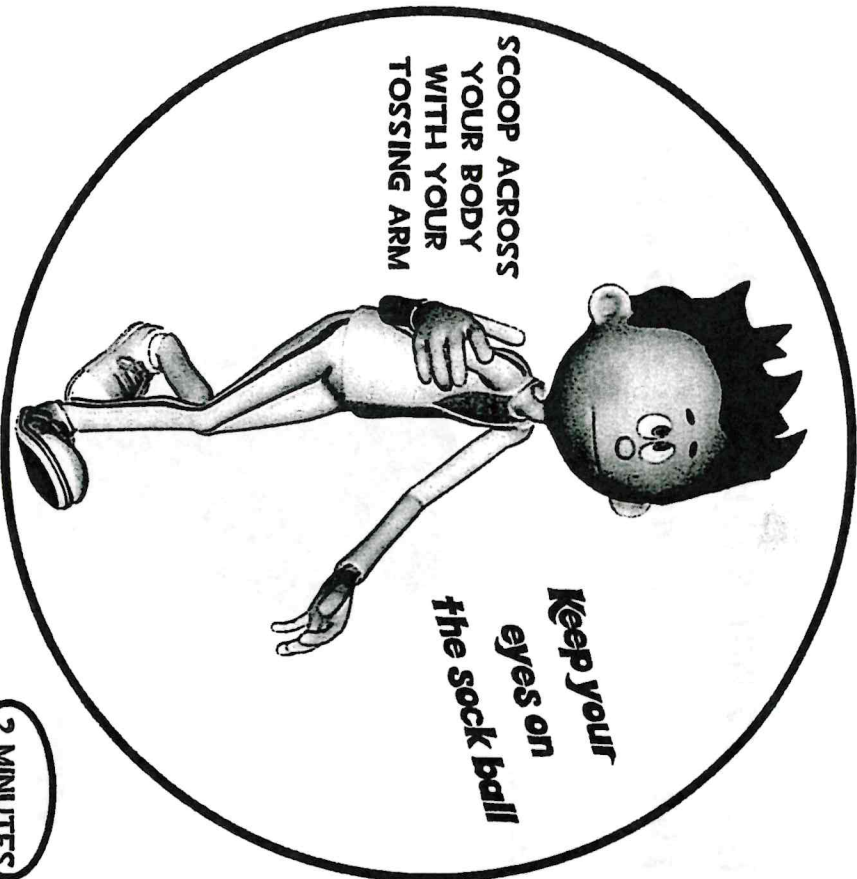

SCOOP ACROSS  
YOUR BODY  
WITH YOUR  
TOSSING ARM

*Keep your  
eyes on  
the sock ball*

2 MINUTES

Toss the sock ball across your body from 1 hand to the other. The sock ball should travel in a rainbow shape.

3

CATCHING

# TOSS/CLAP/CATCH

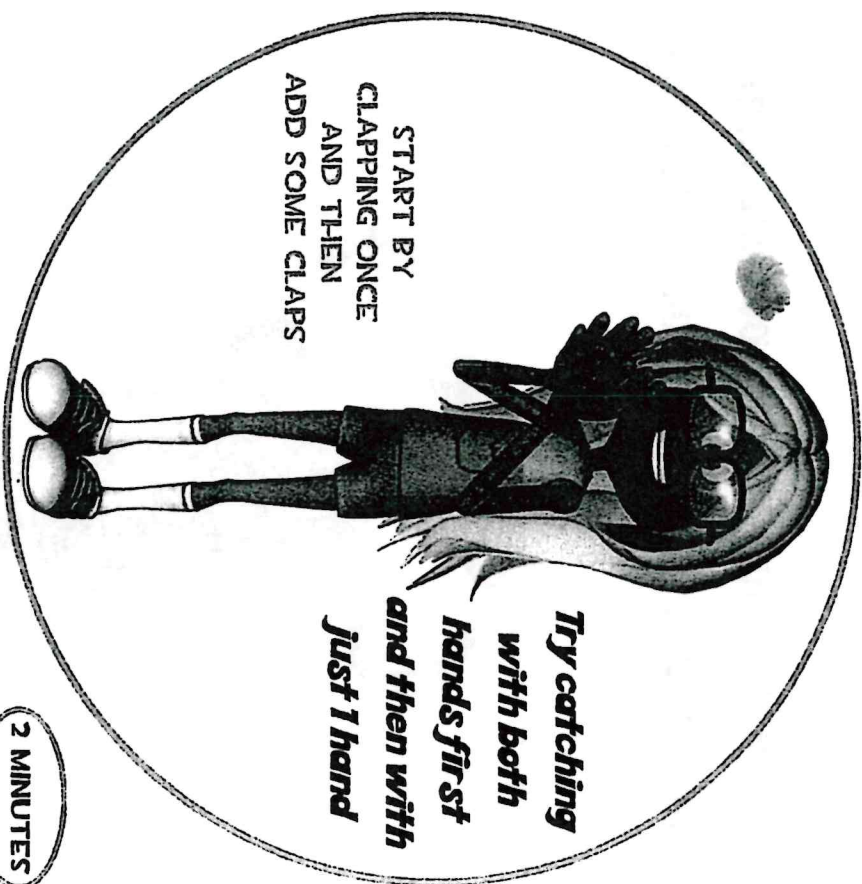

START BY  
CLAPPING ONCE  
AND THEN  
ADD SOME CLAPS

*Try catching  
with both  
hands first  
and then with  
just 1 hand*

2 MINUTES

Toss the sock ball up in the air and clap once or a few times before you catch it.

4

CATCHING

PE AMI  
Ody 1

# TOSS/TOUCH/CATCH

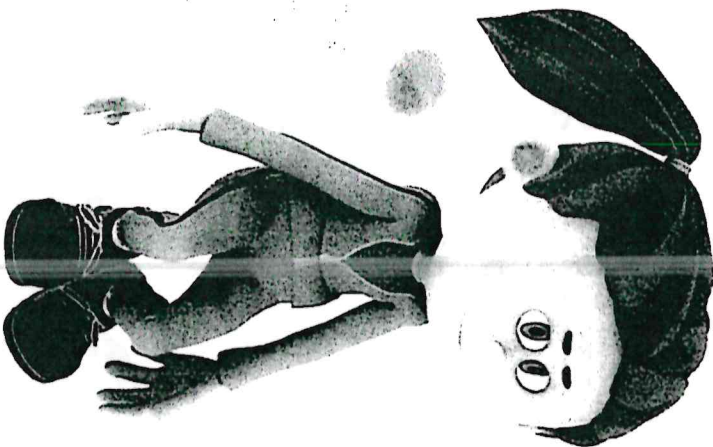

**Toss**  
**Touch**  
**Catch**

2 MINUTES

Toss the sock ball up in the air and touch the ground before you catch it.

5

CATCHING

# TOSS/TURN/CATCH

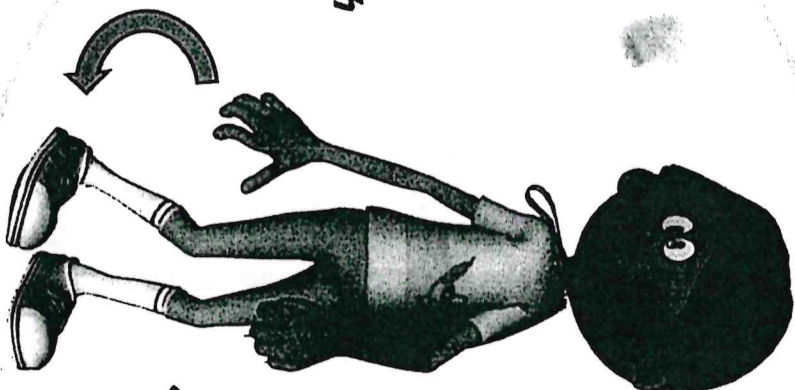

**Toss**  
**Turn**  
**Catch**

TRY TO TURN  
ALL THE  
WAY AROUND

2 MINUTES

Toss the sock ball up in the air and turn around before you catch it.

6

CATCHING

PE AM'S  
Day 1





# AMI - Computer Lab

[tpatterson@seymourschool.net](mailto:tpatterson@seymourschool.net)

Office Hours: 10:00am - 2:00pm Tuesday-Friday

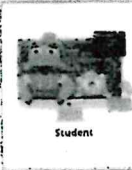
Please spend 15 minutes each AMI day in one of these programs

Grades 2 - 5	
Typesy	<p><a href="http://typesy.com/type/">typesy.com/type/</a> Username and password are the same as your AR username and password.</p>
Tynker	<p><a href="http://tynker.com">tynker.com</a></p>  
ABCya	<p><a href="http://Abcya.com">Abcya.com</a> Login: Username: clab Password: tigers</p>

Grade 1	
TypeTastic	<p><a href="http://Seymour.typetastic.com/login">Seymour.typetastic.com/login</a> Email me for login information if student cannot remember what it is.</p>
Tynker	<p><a href="http://tynker.com">tynker.com</a></p>  
ABCya	<p><a href="http://Abcya.com">Abcya.com</a> Login: Username: clab Password: tigers</p>

Kindergarten	
My Math & My Reading Academy	See attached Getting Started Guide

# My Math Academy®

# My Reading Academy™

## Getting Started Guide

### Welcome, families and caregivers!

We're excited to see your child grow while using *My Math Academy* and *My Reading Academy*! The school-home connection is important, and we hope this Getting Started Guide provides the tools you need to successfully support your child in using Age of Learning's programs at home.

### STEP 1: Set Up Free Home Access

You can set up free home access to Age of Learning's programs using the Redemption Code on the Welcome Letter from your child's classroom teacher:

1. Go to <https://Educate.AgeofLearning.com/Parent/Redeem/> and select your preferred language.
2. Enter your Redemption Code in the box.
3. Click **Submit**.
4. Follow the prompts to create your username and password for the Age of Learning products assigned to you.

### STEP 2: Using Age of Learning's Programs

To use *My Math Academy* and *My Reading Academy* at home, follow these steps:

1. Open your preferred browser and go to URL: [Login.AgeofLearning.com](https://Login.AgeofLearning.com)
2. Log in with the email address and password you entered when activating your accounts.
3. Click on your child's profile and their passcode, and then select *My Math Academy* or *My Reading Academy* to begin gameplay.

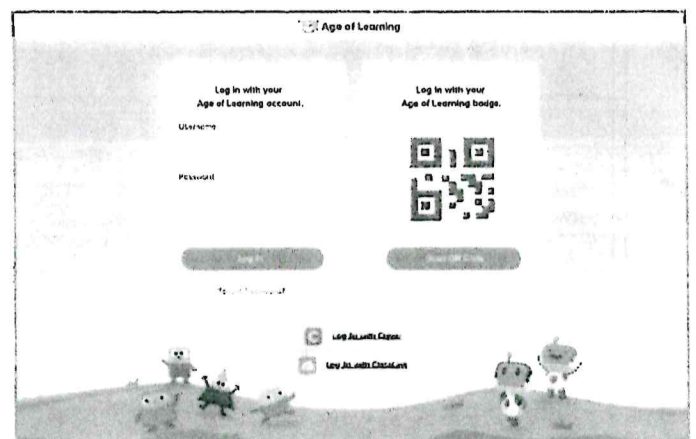

Continued on the back





**Follow these steps to add the My Math Academy and/or My Reading Academy web link to your iPhone home screen:**

1. Open a web browser (such as Safari).
2. Go to our website: [Login.AgeofLearning.com](https://Login.AgeofLearning.com)
3. Tap the **Share** button on the bottom of the page. It looks like a square with an arrow pointing out of the top.
4. In the list of options that appear, scroll down until you see **Add to Home Screen**. Tap this.
5. Choose a name for the website shortcut on your home screen. Click **Add** when you're done.
6. Now tap the new shortcut on your home screen, and it will open the website in its own navigation window.

### STEP 3: Access the Caregiver Center

With the Caregiver Center, you can track your child's usage both at school and at home, review their learning milestones, and find activities to support learning areas where they may need additional support. To access the Caregiver Center, follow these steps:

1. Go to <https://Educate.AoFL.com>
2. Log in with your username and password.
3. If you have multiple children, please select the student's name you want to view.

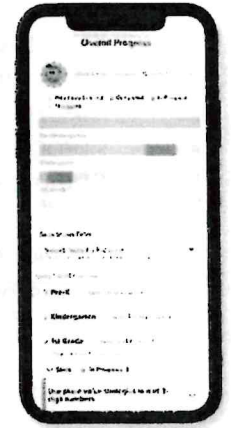

**SUPPORT                      ENCOURAGE                      MOTIVATE**

Support independent play by encouraging your child to use the programs independently.

Encourage your child to use the programs during available free time, to help them reach their goal of 45–60 minutes of use per week!

Motivate your child with small rewards for reaching their weekly usage goal!



**Access the Help Center to Learn More!**  
[www.AgeofLearning.com/Caregivers](http://www.AgeofLearning.com/Caregivers)



*Join the Conversation!*  
**@AgeofLearning**

Dear Caregivers,

We are excited to share a winter break incentive program for *My Math Academy*<sup>®</sup> and *My Reading Academy*<sup>™</sup> designed to extend your child's learning over the holidays.

*My Math Academy* and *My Reading Academy* are adaptive, research-backed programs for pre-K through 2nd grade students. These personalized programs support the individual learning needs of each student, helping them build confidence and develop essential math and reading skills.

Access to these programs is not limited to school. Enclosed are some materials to assist you in setting up your child's account on a home device. Students can access the programs at home in two ways:

**1. QR Code**

- Use this login method if a QR code is attached to this letter.

**2. Redemption Code**

- Follow the Caregiver Getting Started Guide for more information.

We'd love for you to encourage your student to log in over winter break and work in each program. This will give you a glimpse into what your child experiences in the classroom, as well as offering you information on their progress. Due to the adaptability of these programs, please be sure your student answers each question on their own, as extra help can affect the academic level of their experience.

If you would like more information on *My Math Academy* and *My Reading Academy* or have additional questions, please visit our Caregiver Help Center at [AgeofLearning.com/Caregivers](https://AgeofLearning.com/Caregivers).

Thank you for your continued support of your child's education!

Sincerely,  
Mrs. Patterson  
Seymour Elementary



Learn More!

[AgeofLearning.com/Caregivers](https://AgeofLearning.com/Caregivers)

# Music AMI Day 2

Teacher: Mrs. Rechtfertig



Email: [arechtfertig@seymourschool.net](mailto:arechtfertig@seymourschool.net)

Office hours: 9am-1pm

Name: \_\_\_\_\_

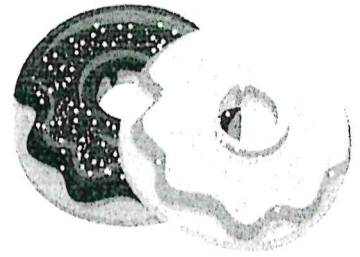

Sometimes notes are placed on a LINE like this:

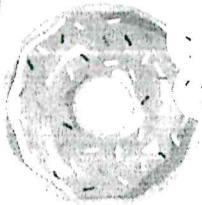
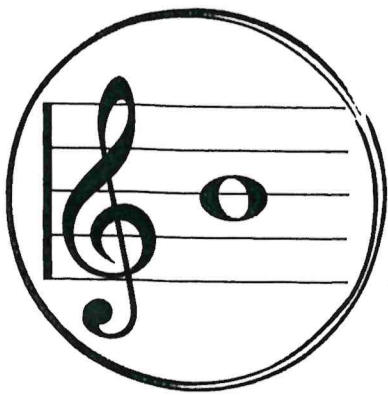

Sometimes notes are placed in a SPACE like this:

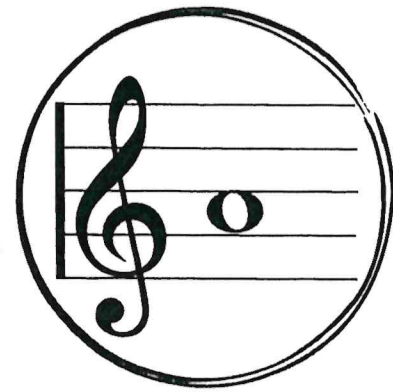

To determine where each note is on the staff, you count from the **BOTTOM** to the **TOP**.

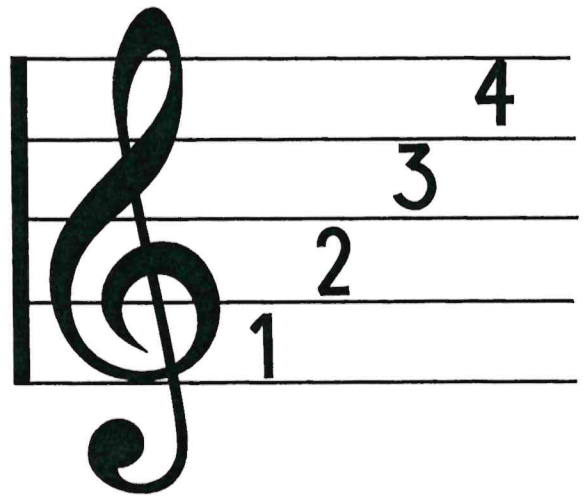
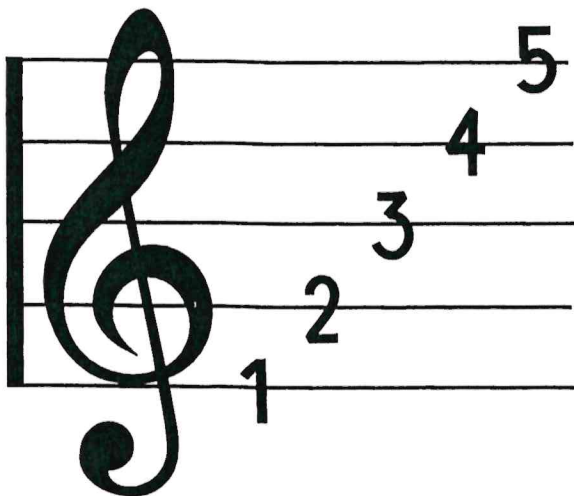



Name: \_\_\_\_\_

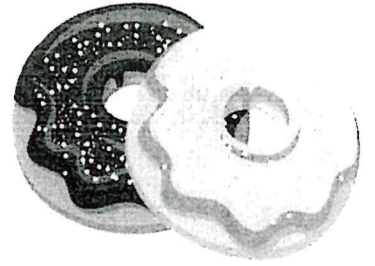

Directions: Identify whether the pitch on the plate is on a line or in a space.  
Add frosting to the donut with the correct letter by shading or coloring it in.

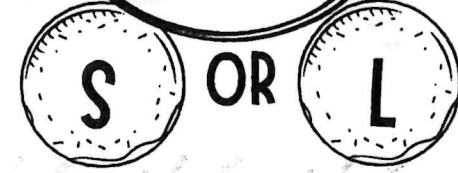
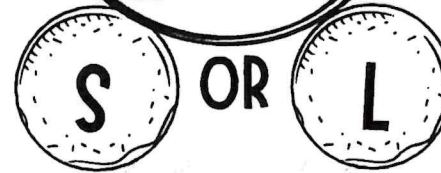
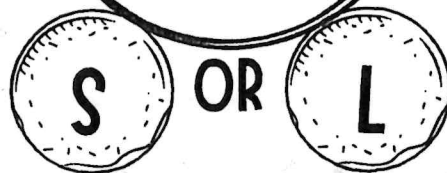
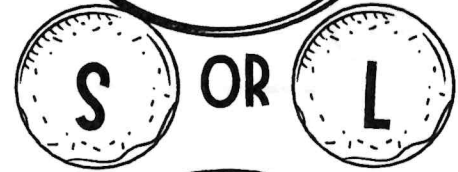
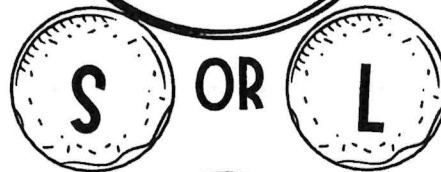
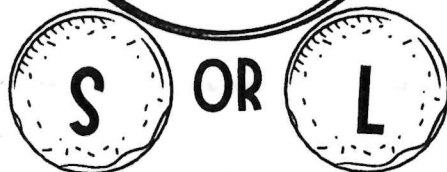
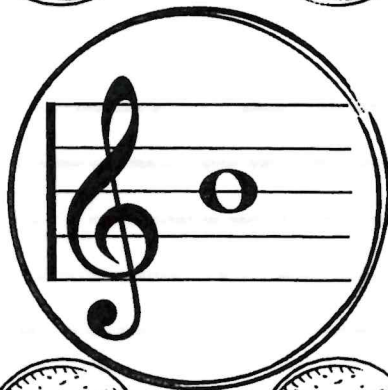
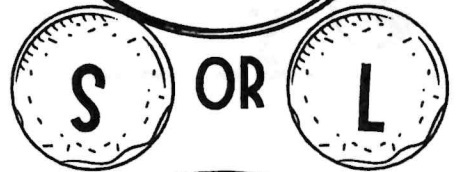
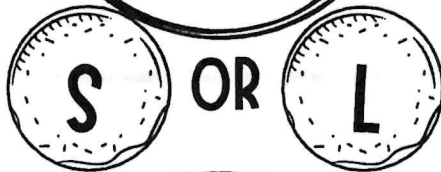
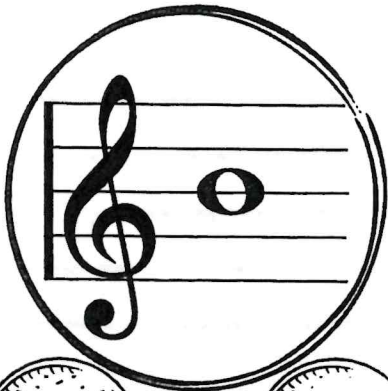



Name: \_\_\_\_\_

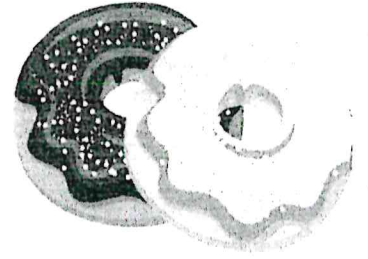

Directions: Identify whether the pitches on the staff are on a line or in a space. Write L for line or S for space below each cup of hot chocolate.

Staff 1: Treble clef. Pitches: Cup 1 on line 1, Cup 2 on space 1, Cup 3 on line 2, Cup 4 on space 2, Cup 5 on line 3, Cup 6 on space 3, Cup 7 on line 4, Cup 8 on space 4, Cup 9 on line 5, Cup 10 on space 5.

Staff 2: Treble clef. Pitches: Cup 1 on line 1, Cup 2 on space 1, Cup 3 on line 2, Cup 4 on space 2, Cup 5 on line 3, Cup 6 on space 3, Cup 7 on line 4, Cup 8 on space 4, Cup 9 on line 5, Cup 10 on space 5.

Staff 3: Treble clef. Pitches: Cup 1 on line 1, Cup 2 on space 1, Cup 3 on line 2, Cup 4 on space 2, Cup 5 on line 3, Cup 6 on space 3, Cup 7 on line 4, Cup 8 on space 4, Cup 9 on line 5, Cup 10 on space 5.

# Kindergarten

## Day 3



Name: \_\_\_\_\_

# A Little Bit of Winter

1. Scan the story next to the book.  
Listen to the story.

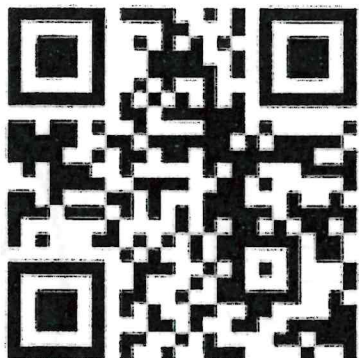
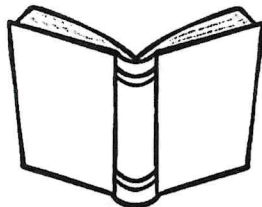

2. Scan the code to hear the instructions.

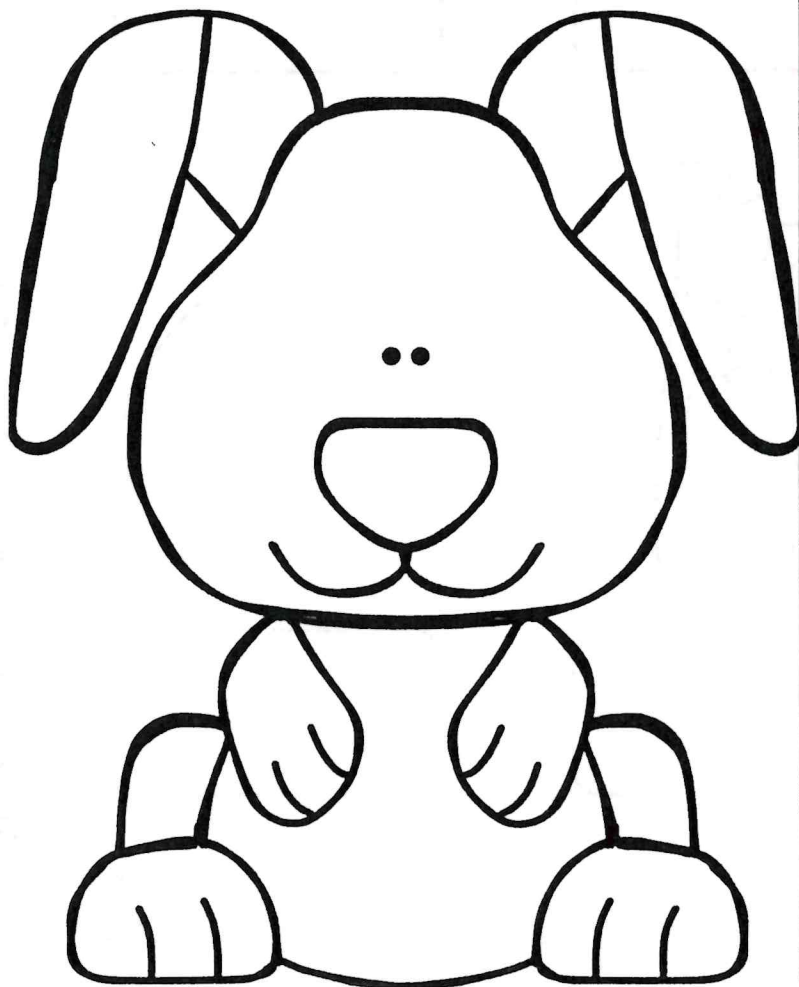
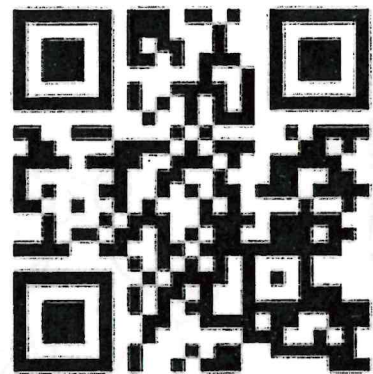

Name: \_\_\_\_\_

# Label It!

Look at each of the pictures. Say the word then write the sounds to make a CVC word.

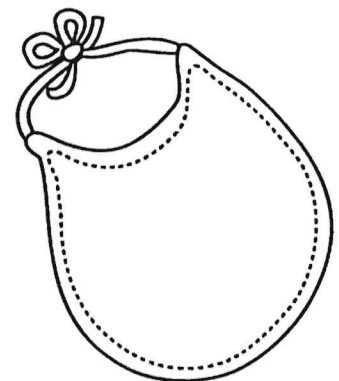
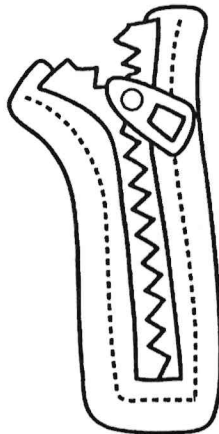
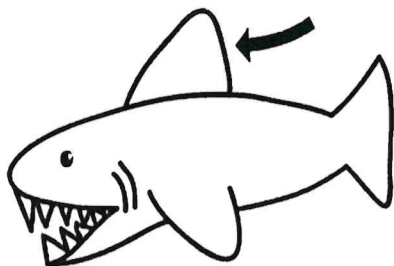
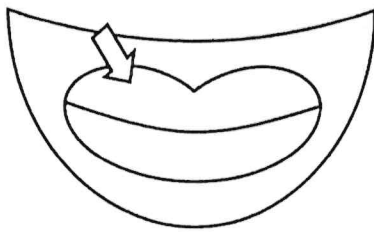



Name: \_\_\_\_\_

# LITTLE PIG

Little pig likes to dig. He will dig and dig. The kid can see the pig dig. The kid said, "Do not dig, little pig!" Little pig is sad. He likes to dig.

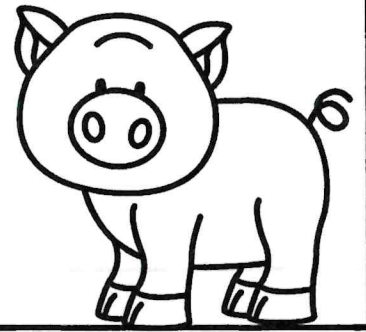

Who likes to dig?

little kid

little pig

little dog

Who said, "Do not dig, little pig"?

the kid

the mom

the pig

How does little pig feel?

---

---

---

# Fab 5 for Writing



Stretch out your words.

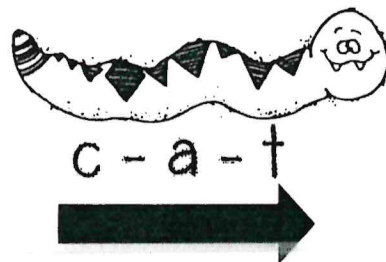

Use capital letters at the beginning of your sentences and for proper nouns.

My name is Sam.



Use finger space.

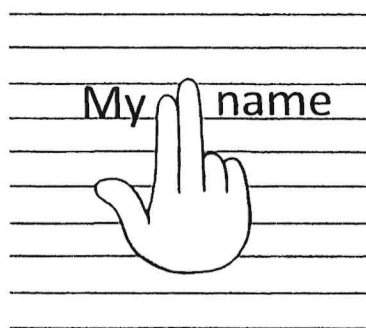

Use punctuation marks at the end of your sentences.

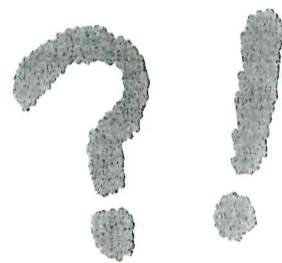

Check your work.  
Does your writing make sense?



Name: \_\_\_\_\_

# Writing

1. Color the picture
2. Use it to write about what you see.
3. Write 2 sentences.

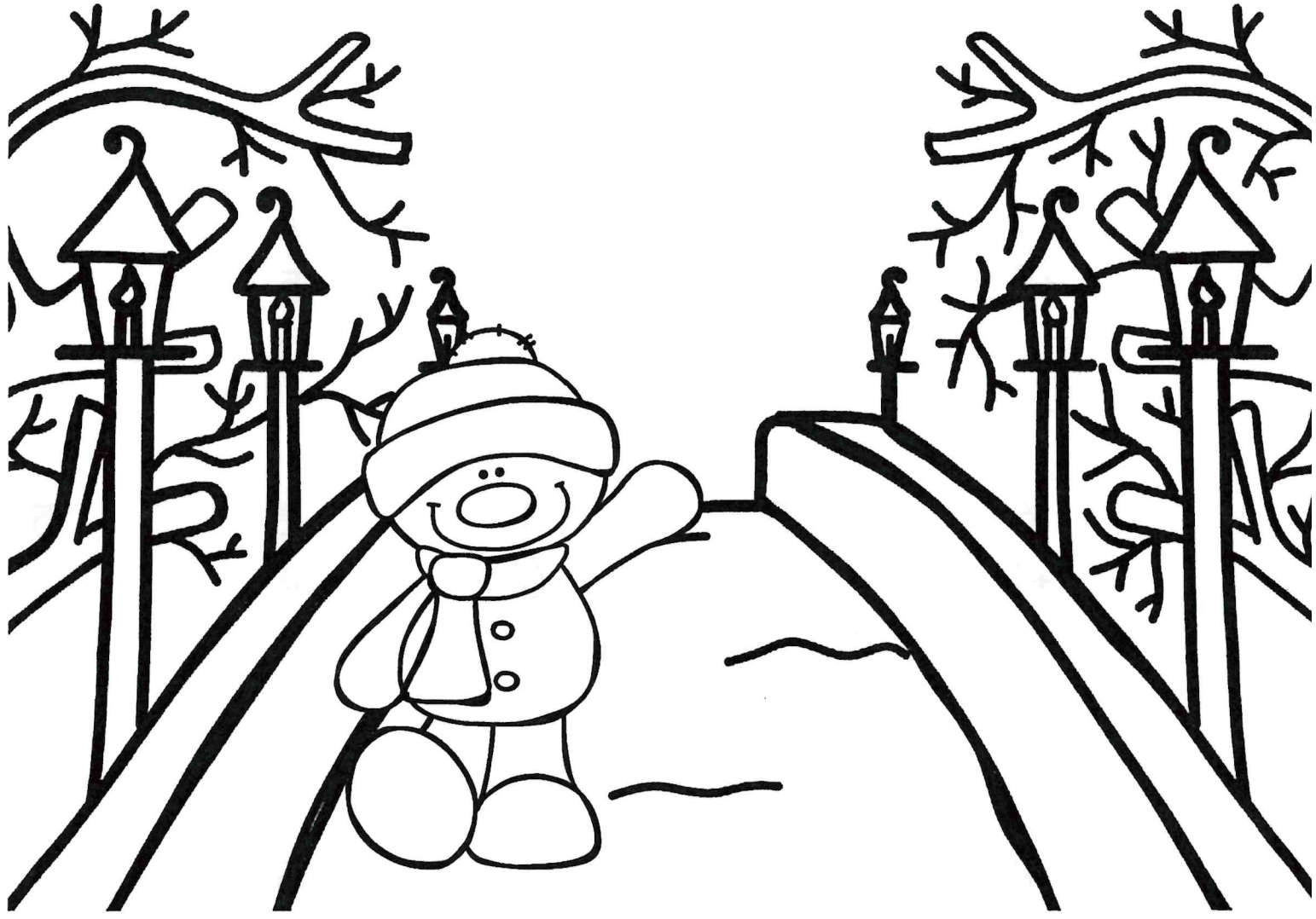

---

---

---

---

---

---

---

---

Name: \_\_\_\_\_

Date: \_\_\_\_\_

## Addition Worksheets

$$\begin{array}{r} 2 \\ +4 \\ \hline \end{array}$$

$$\begin{array}{r} 2 \\ +1 \\ \hline \end{array}$$

$$\begin{array}{r} 4 \\ +4 \\ \hline \end{array}$$

$$\begin{array}{r} 1 \\ +0 \\ \hline \end{array}$$

$$\begin{array}{r} 3 \\ +1 \\ \hline \end{array}$$

$$\begin{array}{r} 1 \\ +5 \\ \hline \end{array}$$

$$\begin{array}{r} 2 \\ +5 \\ \hline \end{array}$$

$$\begin{array}{r} 2 \\ +3 \\ \hline \end{array}$$

$$\begin{array}{r} 4 \\ +5 \\ \hline \end{array}$$

$$\begin{array}{r} 0 \\ +0 \\ \hline \end{array}$$

$$\begin{array}{r} 6 \\ +1 \\ \hline \end{array}$$

$$\begin{array}{r} 5 \\ +2 \\ \hline \end{array}$$

$$\begin{array}{r} 3 \\ +0 \\ \hline \end{array}$$

$$\begin{array}{r} 2 \\ +4 \\ \hline \end{array}$$

$$\begin{array}{r} 5 \\ +4 \\ \hline \end{array}$$

$$\begin{array}{r} 5 \\ +2 \\ \hline \end{array}$$

$$\begin{array}{r} 1 \\ +2 \\ \hline \end{array}$$

$$\begin{array}{r} 1 \\ +1 \\ \hline \end{array}$$

$$\begin{array}{r} 2 \\ +5 \\ \hline \end{array}$$

$$\begin{array}{r} 2 \\ +1 \\ \hline \end{array}$$

$$\begin{array}{r} 5 \\ +5 \\ \hline \end{array}$$

$$\begin{array}{r} 5 \\ +1 \\ \hline \end{array}$$

$$\begin{array}{r} 5 \\ +2 \\ \hline \end{array}$$

$$\begin{array}{r} 3 \\ +5 \\ \hline \end{array}$$

$$\begin{array}{r} 6 \\ +4 \\ \hline \end{array}$$

Name: \_\_\_\_\_

Date: \_\_\_\_\_

Date: \_\_\_\_\_

## Subtraction worksheets

$7-2=$

$1-0=$

$7-4=$

$2-0=$

$9-5=$

$9-1=$

$2-1=$

$9-3=$

$6-2=$

$2-1=$

$4-4=$

$2-1=$

$10-7=$

$4-2=$

$6-6=$

$4-4=$

$3-1=$

$6-2=$

$7-7=$

$5-3=$

$9-3=$

$10-4=$

$5-2=$

$7-5=$

$7-3=$

$9-6=$

$1-1=$

$9-2=$

$1-0=$

$6-1=$

$6-5=$

$9-7=$

$4-0=$

$9-1=$

$3-2=$





# Kindergarten

## Day 4



Name: \_\_\_\_\_

# The Biggest, Best Snowman

1. Scan the story next to the book.  
Listen to the story.
2. Scan the code to hear the instructions.

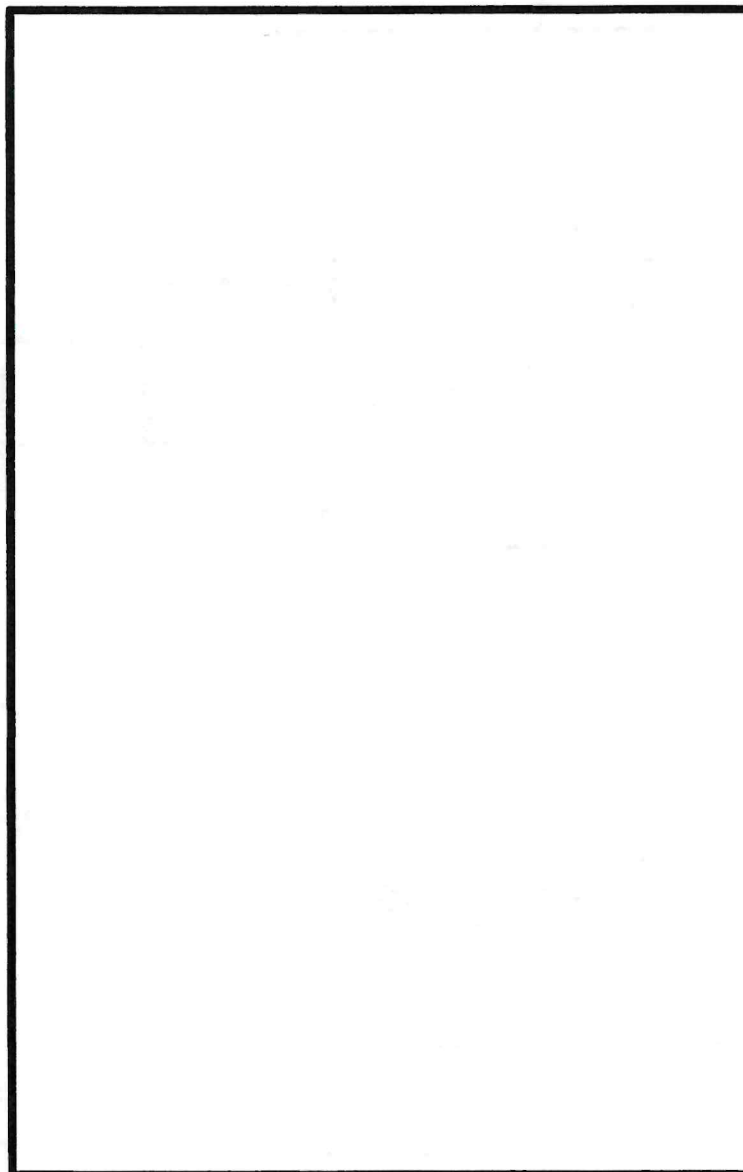
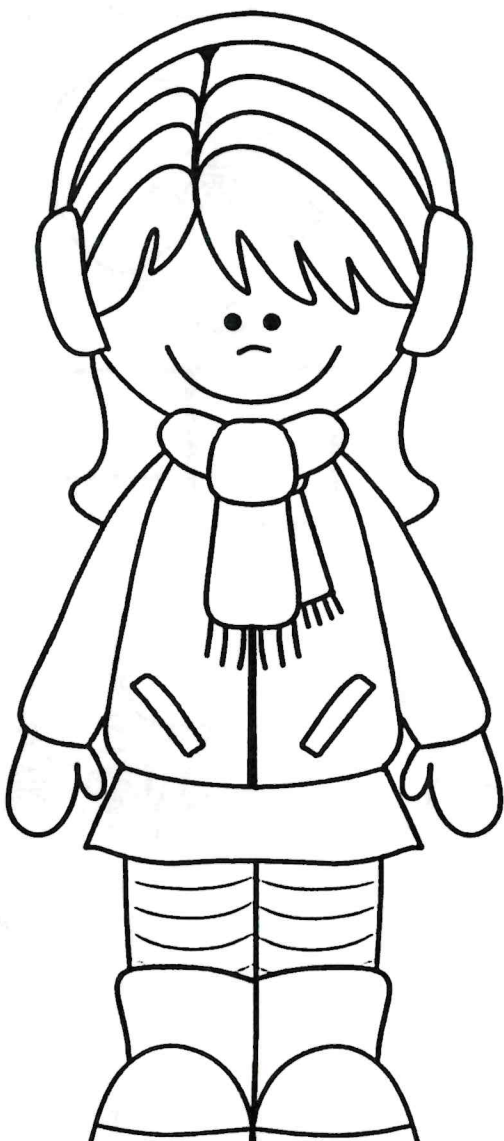
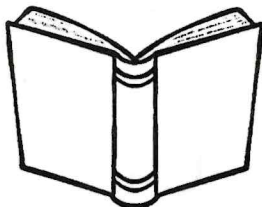

Name: \_\_\_\_\_

ELA

# CVC short o words

Say the picture name. Write one sound in each box for the beginning sound, middle sound and ending sound.

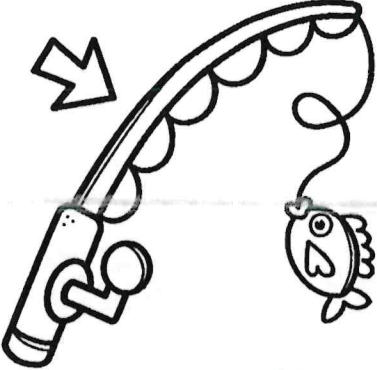

\_\_\_\_\_



\_\_\_\_\_

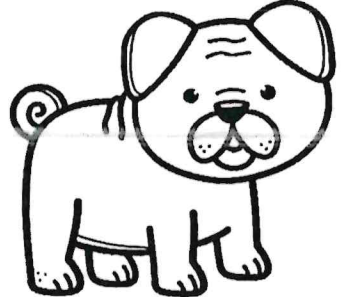

\_\_\_\_\_

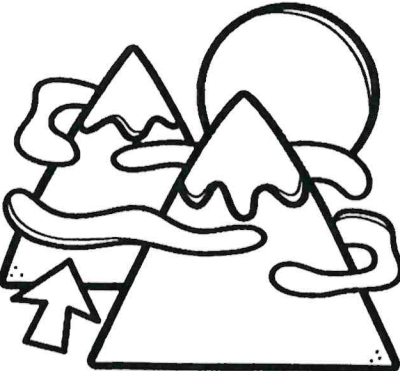

\_\_\_\_\_

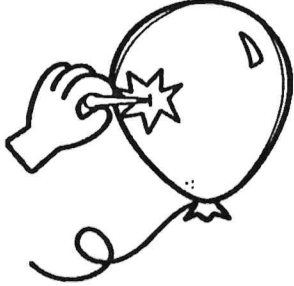

\_\_\_\_\_

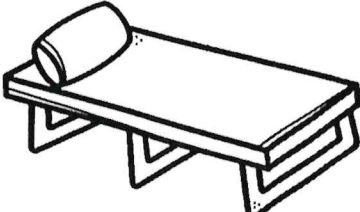

\_\_\_\_\_

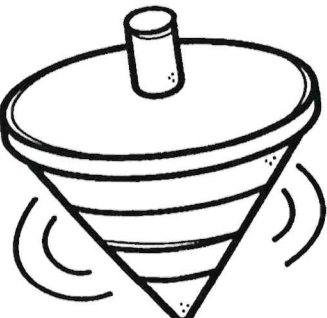

\_\_\_\_\_

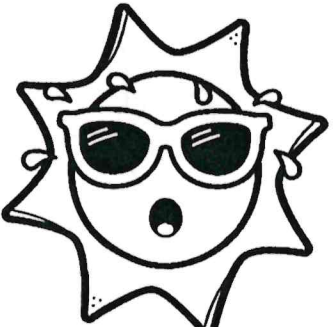

\_\_\_\_\_



Name: \_\_\_\_\_

# FOX AND DOG

The dog is on a log. He can see a fox.  
The fox will jump on the log. The fox  
will sit on the log. The fox and the  
dog sat on the log.

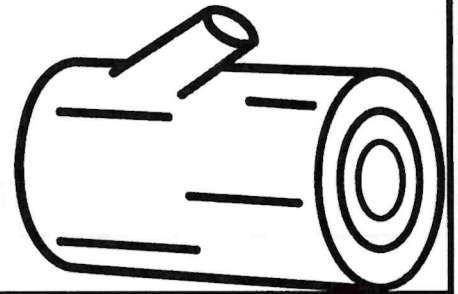

Who did the dog see?

a fox

a dog

a bat

Who will jump on the log?

the cat

the dog

the fox

Who sat on the log?

---

---

---

# Fab 5 for Writing



Stretch out your words.

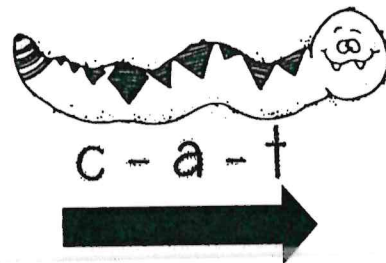

Use capital letters at the beginning of your sentences and for proper nouns.

My name is Sam.

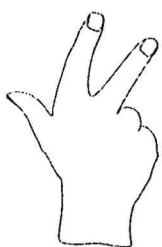

Use finger space.

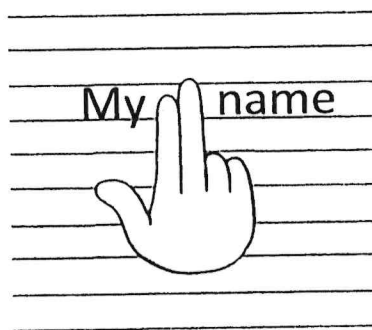

Use punctuation marks at the end of your sentences.

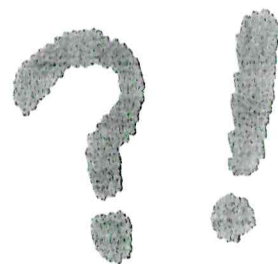

Check your work.  
Does your writing make sense?



Name: \_\_\_\_\_

1. Color the picture

3. Write 2 sentences.

2. Use it to make up a story.



The bus

Name: \_\_\_\_\_

Date: \_\_\_\_\_

Date: \_\_\_\_\_

## Addition Worksheets

$4+5=$

$5+3=$

$1+2=$

$5+2=$

$2+5=$

$1+2=$

$5+5=$

$1+1=$

$4+5=$

$1+2=$

$1+3=$

$5+2=$

$6+3=$

$4+1=$

$0+4=$

$0+5=$

$2+0=$

$2+2=$

$5+0=$

$6+2=$

$6+0=$

$5+5=$

$3+5=$

$2+4=$

$2+1=$

$2+4=$

$2+4=$

$2+2=$

$4+6=$

$5+2=$

$2+3=$

$4+0=$

$2+2=$

$3+2=$

$5+4=$

Name: \_\_\_\_\_

Date: \_\_\_\_\_

Subtraction worksheets

$$\begin{array}{r} 3 \\ -2 \\ \hline \end{array}$$

$$\begin{array}{r} 5 \\ -2 \\ \hline \end{array}$$

$$\begin{array}{r} 5 \\ -4 \\ \hline \end{array}$$

$$\begin{array}{r} 1 \\ -0 \\ \hline \end{array}$$

$$\begin{array}{r} 1 \\ -1 \\ \hline \end{array}$$

$$\begin{array}{r} 5 \\ -3 \\ \hline \end{array}$$

$$\begin{array}{r} 8 \\ -7 \\ \hline \end{array}$$

$$\begin{array}{r} 9 \\ -1 \\ \hline \end{array}$$

$$\begin{array}{r} 3 \\ -2 \\ \hline \end{array}$$

$$\begin{array}{r} 4 \\ -3 \\ \hline \end{array}$$

$$\begin{array}{r} 7 \\ -2 \\ \hline \end{array}$$

$$\begin{array}{r} 1 \\ -0 \\ \hline \end{array}$$

$$\begin{array}{r} 3 \\ -0 \\ \hline \end{array}$$

$$\begin{array}{r} 5 \\ -4 \\ \hline \end{array}$$

$$\begin{array}{r} 6 \\ -5 \\ \hline \end{array}$$

$$\begin{array}{r} 3 \\ -2 \\ \hline \end{array}$$

$$\begin{array}{r} 5 \\ -3 \\ \hline \end{array}$$

$$\begin{array}{r} 2 \\ -1 \\ \hline \end{array}$$

$$\begin{array}{r} 2 \\ -0 \\ \hline \end{array}$$

$$\begin{array}{r} 5 \\ -4 \\ \hline \end{array}$$

$$\begin{array}{r} 0 \\ -0 \\ \hline \end{array}$$

$$\begin{array}{r} 4 \\ -3 \\ \hline \end{array}$$

$$\begin{array}{r} 5 \\ -4 \\ \hline \end{array}$$

$$\begin{array}{r} 6 \\ -5 \\ \hline \end{array}$$

$$\begin{array}{r} 7 \\ -4 \\ \hline \end{array}$$





# Kindergarten

## Day 5



Name: \_\_\_\_\_

# The Snowy Day

1. Scan the story next to the book.  
Listen to the story.

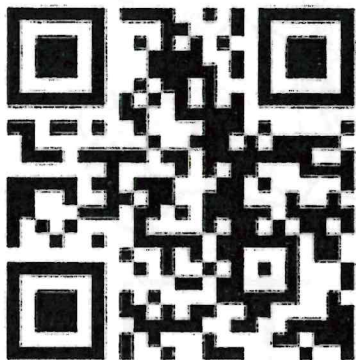
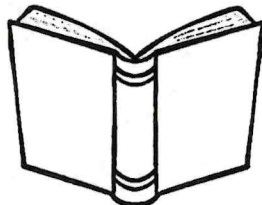

2. Scan the code to hear the instructions.

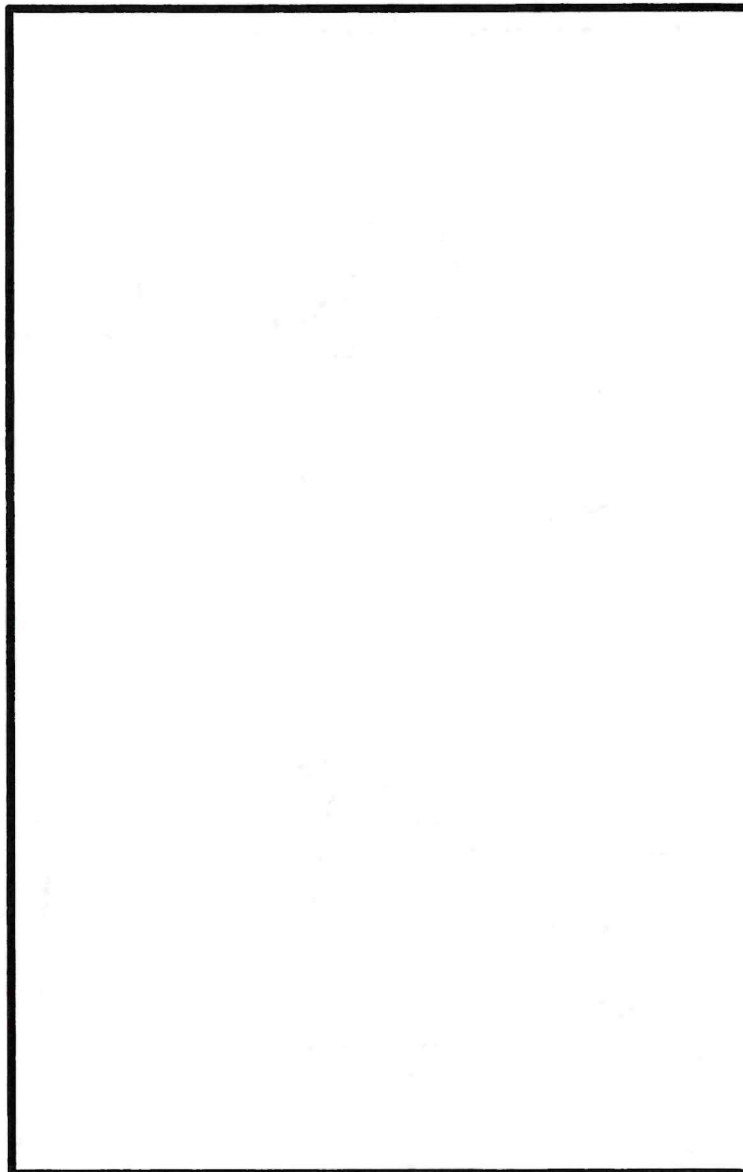
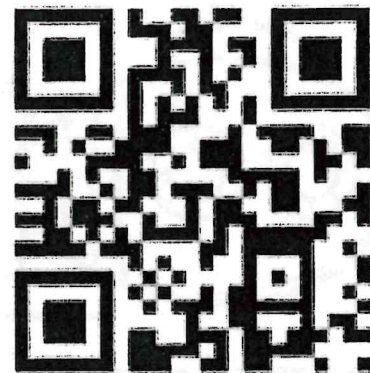

Name: \_\_\_\_\_

ELA

# CVC short u words

Say the picture name. Write one sound in each box for the beginning sound, middle sound and ending sound.

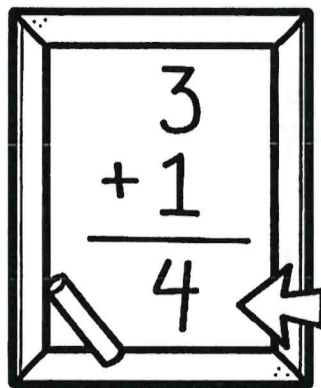
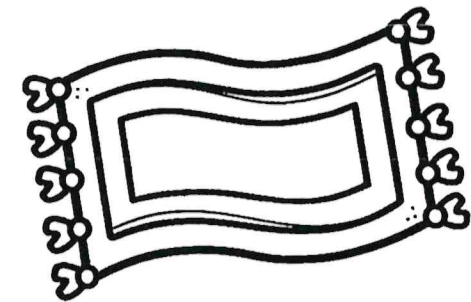
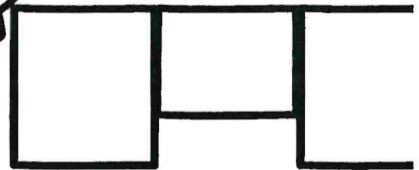
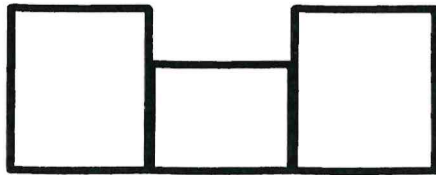
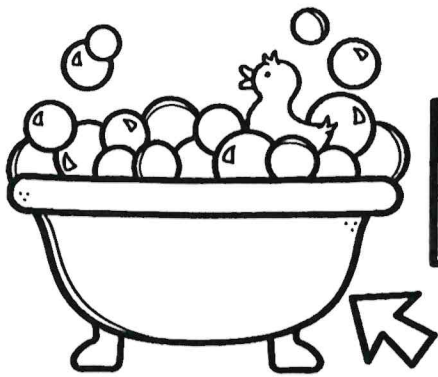
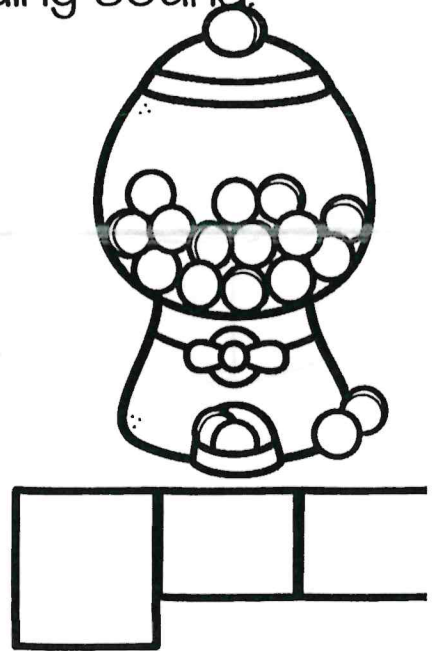
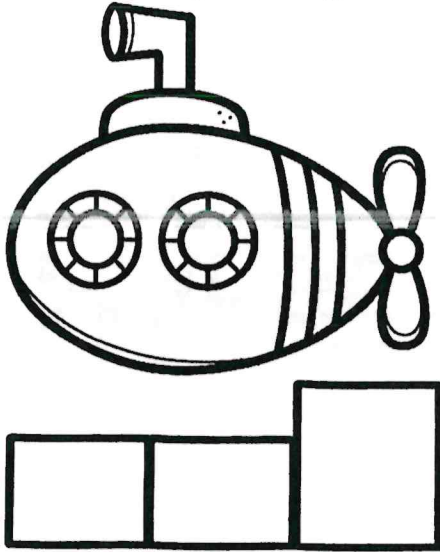



Name: \_\_\_\_\_

# PUP LIKES TO RUN

The pup liked to run in the sun. He ran to the cub. The cub ran with the pup. The pup and the cub had fun in the sun.

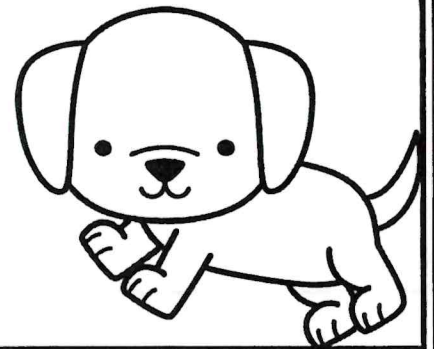

What did the pup like to do?

sit

run

hop

Who ran with the pup?

cub

pup

bug

Who had fun?

---

---

---

# Fab 5 for Writing



Stretch out your words.

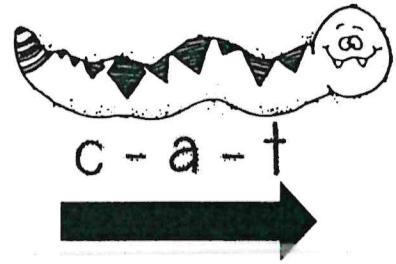

Use capital letters at the beginning of your sentences and for proper nouns.

My name is Sam.



Use finger space.

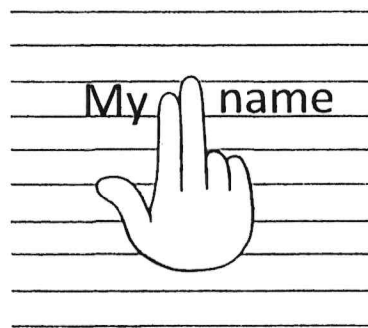

Use punctuation marks at the end of your sentences.

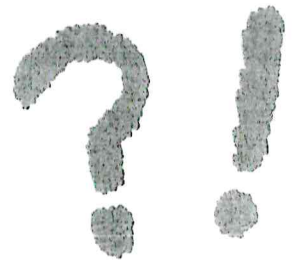

Check your work.  
Does your writing make sense?

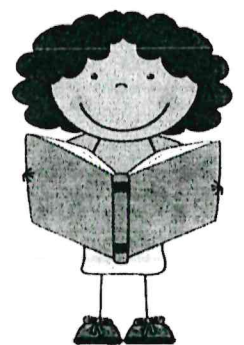

Name: \_\_\_\_\_

1. Color the picture

3. Write 2 sentences

2. Use it to make up a story.



---

---

---

---

---

---

---

---

---

---

Name: \_\_\_\_\_

Date: \_\_\_\_\_

## Addition Worksheets

$6+4=$

$4+5=$

$0+1=$

$6+5=$

$5+2=$

$5+3=$

$4+4=$

$5+1=$

$5+2=$

$5+0=$

$2+2=$

$1+4=$

$2+1=$

$6+0=$

$6+4=$

$4+1=$

$1+6=$

$5+0=$

$2+2=$

$2+1=$

$2+4=$

$3+2=$

$5+1=$

$5+4=$

$1+4=$

$5+4=$

$0+5=$

$3+1=$

$3+6=$

$4+4=$

$5+6=$

$3+5=$

$3+0=$

$6+1=$

$1+6=$

Name: \_\_\_\_\_

Date: \_\_\_\_\_

Date: \_\_\_\_\_

## Subtraction worksheets

$$\begin{array}{r} 3 \\ -3 \\ \hline \end{array}$$

$$\begin{array}{r} 1 \\ -1 \\ \hline \end{array}$$

$$\begin{array}{r} 1 \\ -0 \\ \hline \end{array}$$

$$\begin{array}{r} 6 \\ -5 \\ \hline \end{array}$$

$$\begin{array}{r} 7 \\ -5 \\ \hline \end{array}$$

$$\begin{array}{r} 0 \\ -0 \\ \hline \end{array}$$

$$\begin{array}{r} 7 \\ -0 \\ \hline \end{array}$$

$$\begin{array}{r} 5 \\ -1 \\ \hline \end{array}$$

$$\begin{array}{r} 6 \\ -1 \\ \hline \end{array}$$

$$\begin{array}{r} 6 \\ -5 \\ \hline \end{array}$$

$$\begin{array}{r} 2 \\ -0 \\ \hline \end{array}$$

$$\begin{array}{r} 7 \\ -4 \\ \hline \end{array}$$

$$\begin{array}{r} 7 \\ -5 \\ \hline \end{array}$$

$$\begin{array}{r} 1 \\ -1 \\ \hline \end{array}$$

$$\begin{array}{r} 7 \\ -1 \\ \hline \end{array}$$

$$\begin{array}{r} 6 \\ -6 \\ \hline \end{array}$$

$$\begin{array}{r} 3 \\ -3 \\ \hline \end{array}$$

$$\begin{array}{r} 9 \\ -7 \\ \hline \end{array}$$

$$\begin{array}{r} 3 \\ -3 \\ \hline \end{array}$$

$$\begin{array}{r} 5 \\ -3 \\ \hline \end{array}$$

$$\begin{array}{r} 4 \\ -1 \\ \hline \end{array}$$

$$\begin{array}{r} 8 \\ -3 \\ \hline \end{array}$$

$$\begin{array}{r} 6 \\ -3 \\ \hline \end{array}$$

$$\begin{array}{r} 1 \\ -0 \\ \hline \end{array}$$

$$\begin{array}{r} 3 \\ -1 \\ \hline \end{array}$$





# Kindergarten

## Day 6



Name: \_\_\_\_\_

# There Was a Cold Lady Who Swallowed Some Snow

1. Scan the story next to the book.  
Listen to the story.
2. Scan the code to hear the instructions.

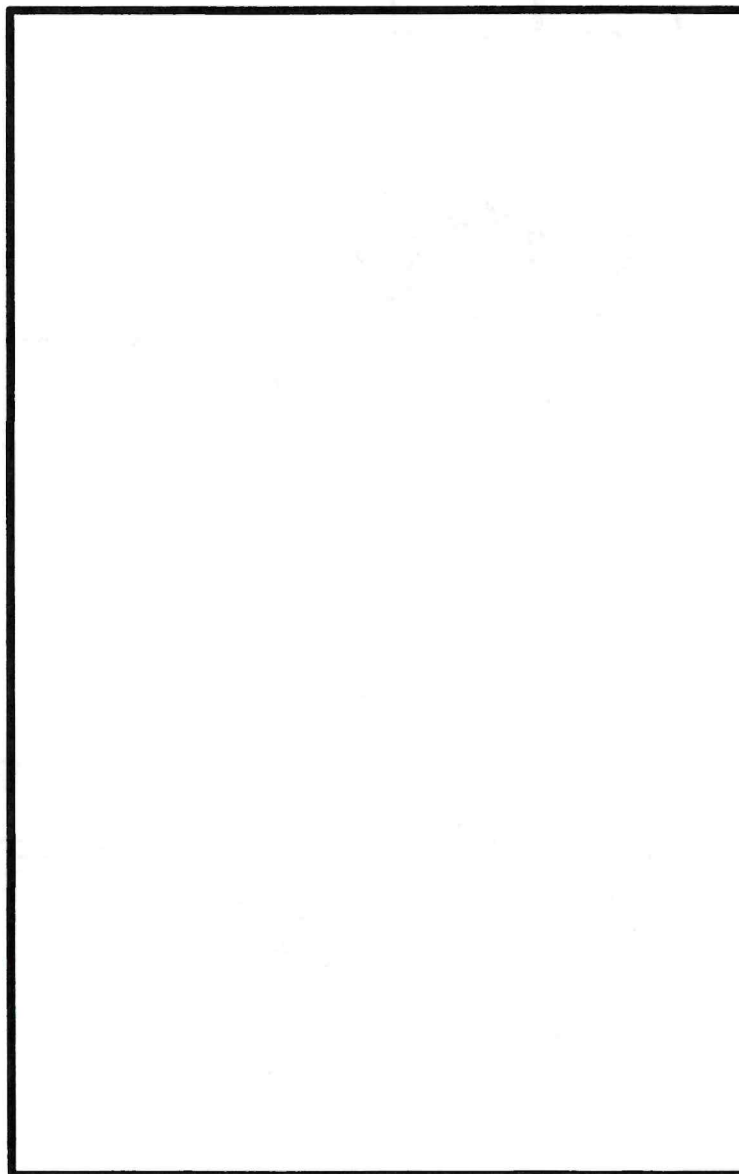
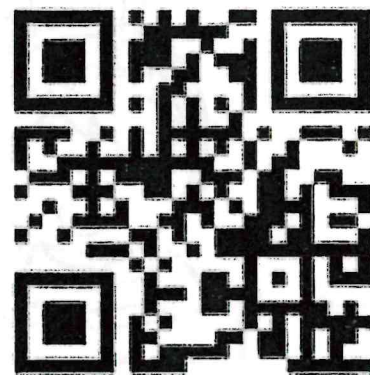
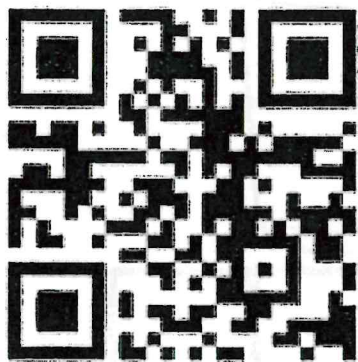
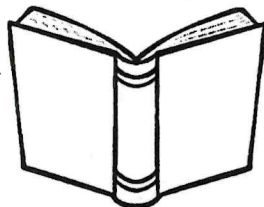

Name: \_\_\_\_\_

ELA

# CVC short u words

Say the picture name. Write one sound in each box for the beginning sound, middle sound and ending sound.

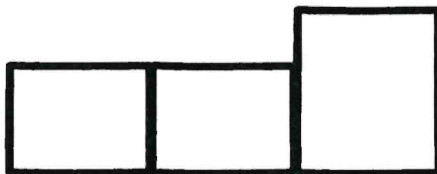
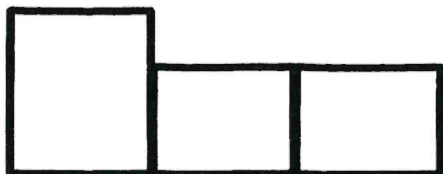
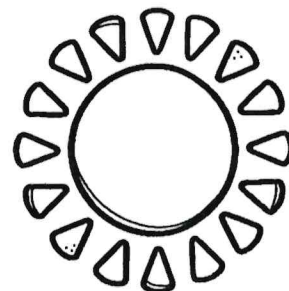
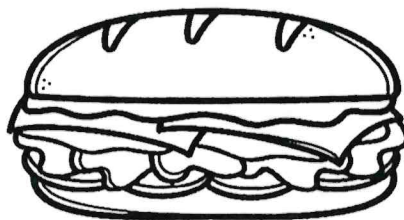
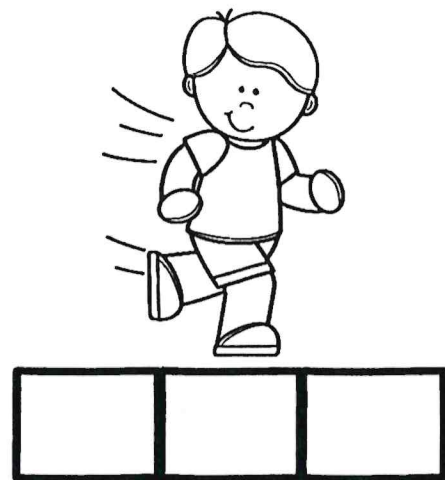
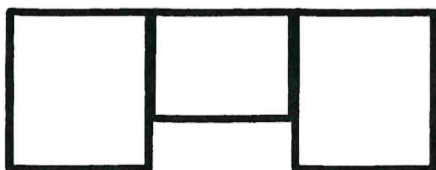
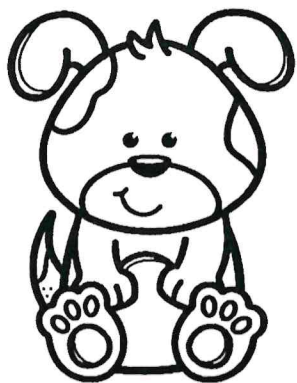
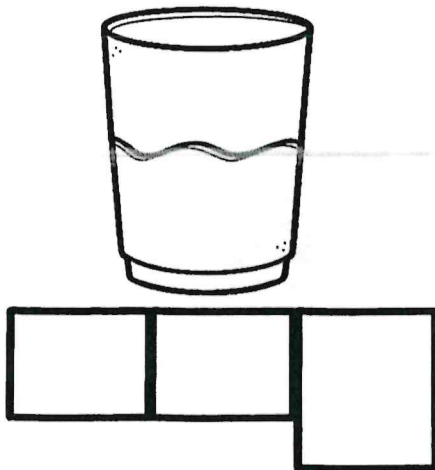



Name: \_\_\_\_\_

# JAM

I do not like jam! I do not like jam on ham. I do not like jam on a yam. Do you like jam on a bun? I do not like jam on a bun!

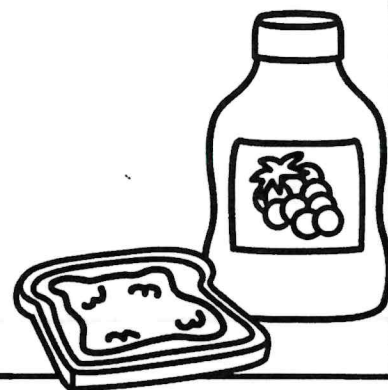

What does I not like?

yams

ham

jam

Draw and label what I do not like jam on:

--	--	--

# Fab 5 for Writing



Stretch out your words.

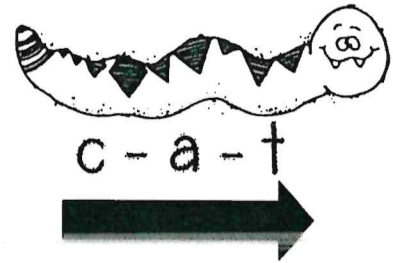

Use capital letters at the beginning of your sentences and for proper nouns.

My name is Sam.



Use finger space.

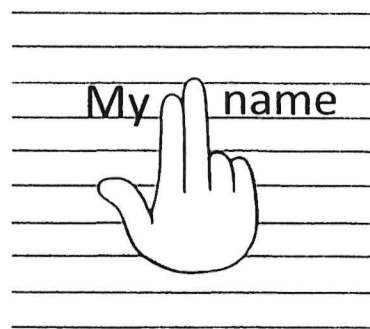

Use punctuation marks at the end of your sentences.

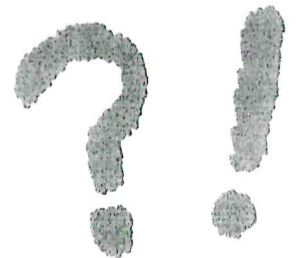

Check your work.  
Does your writing make sense?



Name: \_\_\_\_\_

# Writing

1. Color the picture
2. Use it to make up a story.
3. Write 2 sentences.

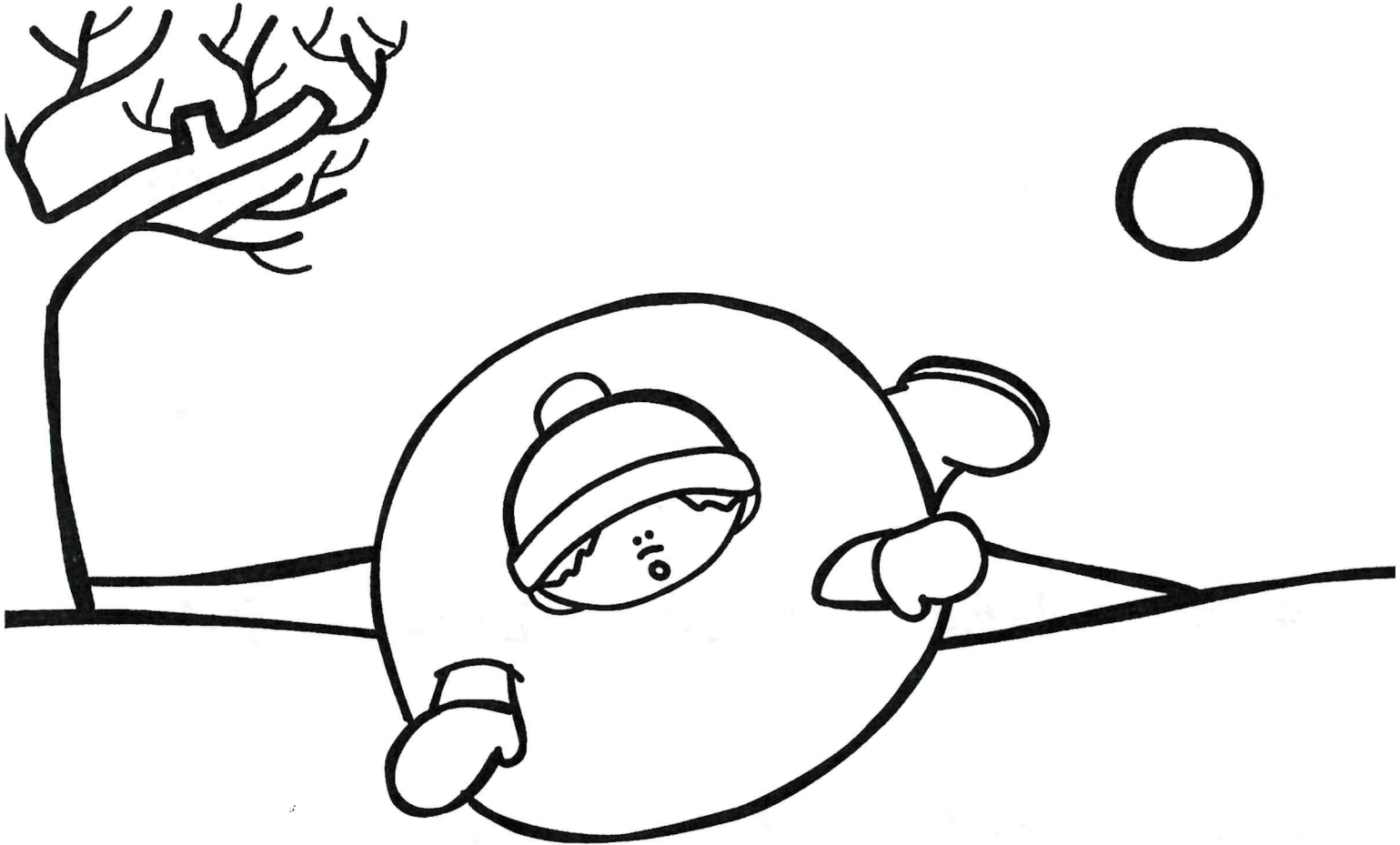

---

---

---

---

---

---

---

---

---

---

Name: \_\_\_\_\_

Grade: \_\_\_\_\_

Date: \_\_\_\_\_

## Addition Worksheets

$6+4=$

$4+5=$

$0+1=$

$6+5=$

$5+2=$

$5+3=$

$4+4=$

$5+1=$

$5+2=$

$5+0=$

$2+2=$

$1+4=$

$2+1=$

$6+0=$

$6+4=$

$4+1=$

$1+6=$

$5+0=$

$2+2=$

$2+1=$

$2+4=$

$3+2=$

$5+1=$

$5+4=$

$1+4=$

$5+4=$

$0+5=$

$3+1=$

$3+6=$

$4+4=$

$5+6=$

$3+5=$

$3+0=$

$6+1=$

$1+6=$

Name: \_\_\_\_\_

Date: \_\_\_\_\_

## Subtraction worksheets

3

-1

\_\_\_\_\_

8

-0

\_\_\_\_\_

7

-2

\_\_\_\_\_

4

-3

\_\_\_\_\_

7

-0

\_\_\_\_\_

3

-3

\_\_\_\_\_

6

-5

\_\_\_\_\_

5

-2

\_\_\_\_\_

5

-5

\_\_\_\_\_

3

-2

\_\_\_\_\_

3

-1

\_\_\_\_\_

1

-0

\_\_\_\_\_

3

-1

\_\_\_\_\_

3

-3

\_\_\_\_\_

3

-3

\_\_\_\_\_

2

-1

\_\_\_\_\_

3

-3

\_\_\_\_\_

7

-6

\_\_\_\_\_

7

-6

\_\_\_\_\_

9

-4

\_\_\_\_\_

9

-5

\_\_\_\_\_

3

-2

\_\_\_\_\_

0

-0

\_\_\_\_\_

5

-3

\_\_\_\_\_

1

-1

\_\_\_\_\_



